

SD2500C..K SERIES

STANDARD RECOVERY DIODES

Hockey Puk Version

Features

- Wide current range
- High voltage ratings up to 2500V
- High surge current capabilities
- Diffused junction
- Hockey Puk version
- Case style DO-200AC (K-PUK)

Typical Applications

- Converters
- Power supplies
- Machine tool controls
- High power drives
- Medium traction applications

3000A

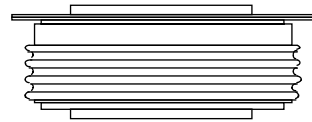

case style DO-200AC (K-PUK)

Major Ratings and Characteristics

Parameters	SD2500C..K	Units	
$I_{F(AV)}$	3000	A	
@ T_{hs}	55	°C	
$I_{F(RMS)}$	5000	A	
@ T_{hs}	25	°C	
I_{FSM}	@ 50Hz	31000	A
	@ 60Hz	32460	A
I^2t	@ 50Hz	4810	KA ² s
	@ 60Hz	4390	KA ² s
V_{RRM} range	1200 to 2500	V	
T_J	- 40 to 180	°C	

SD2500C..K Series

Bulletin I2089 rev. B 04/00

International
 Rectifier

ELECTRICAL SPECIFICATIONS

Voltage Ratings

Type number	Voltage Code	V_{RRM} : maximum repetitive peak reverse voltage V	V_{RSM} : maximum non-repetitive peak rev. voltage V	I_{RRM} max. @ $T_J = 180^\circ\text{C}$ mA
SD2500C..K	12	1200	1300	75
	16	1600	1700	
	20	2000	2100	
	25	2500	2600	

Forward Conduction

Parameter	SD2500C..K	Units	Conditions
$I_{F(AV)}$ Max. average forward current @ Heatsink temperature	3000 (1550)	A	180° conduction, half sine wave
	55 (85)	°C	Double side (single side) cooled
$I_{F(RMS)}$ Max. RMS forward current	5000	A	@ 25°C heatsink temperature double side cooled
I_{FSM} Max. peak, one-cycle forward, non-repetitive surge current	31000	A	t = 10ms No voltage reappplied
	32460		t = 8.3ms reappplied
	26050		t = 10ms 100% V_{RRM} reappplied
	27300		t = 8.3ms reappplied
I^2t Maximum I^2t for fusing	4810	KA ² s	t = 10ms No voltage reappplied
	4390		t = 8.3ms reappplied
	3400		t = 10ms 100% V_{RRM} reappplied
	3100		t = 8.3ms reappplied
$I^2\sqrt{t}$ Maximum $I^2\sqrt{t}$ for fusing	48100	KA ² √s	t = 0.1 to 10ms, no voltage reappplied
$V_{F(TO)1}$ Low level value of threshold voltage	0.76	V	(16.7% x π x $I_{F(AV)}$) < I < π x $I_{F(AV)}$, $T_J = T_J$ max.
$V_{F(TO)2}$ High level value of threshold voltage	0.97		(I > π x $I_{F(AV)}$), $T_J = T_J$ max.
r_{f1} Low level value of forward slope resistance	0.16	mΩ	(16.7% x π x $I_{F(AV)}$) < I < π x $I_{F(AV)}$, $T_J = T_J$ max.
r_{f2} High level value of forward slope resistance	0.13		(I > π x $I_{F(AV)}$), $T_J = T_J$ max.
V_{FM} Max. forward voltage drop	1.41	V	$I_{pk} = 4000\text{A}$, $T_J = T_J$ max, $t_p = 10\text{ms}$ sinusoidal wave

Thermal and Mechanical Specifications

Parameter	SD2500C..K	Units	Conditions
T _J Max. junction operating temperature range	-40 to 180	°C	
T _{stg} Max. storage temperature range	-55 to 200		
R _{thJ-hs} Max. thermal resistance, junction to heatsink	0.042 0.020	K/W	DC operation single side cooled DC operation double side cooled
F Mounting force, ± 10%	22250 (2250)	N (Kg)	
wt Approximate weight	425	g	
Case style	DO-200AC(K-PUK)		See Outline Table

ΔR_{thJ-hs} Conduction

(The following table shows the increment of thermal resistance R_{thJ-hs} when devices operate at different conduction angles than DC)

Conduction angle	Sinusoidal conduction		Rectangular conduction		Units	Conditions
	Single Side	Double Side	Single Side	Double Side		
180°	0.002	0.002	0.001	0.001	K/W	T _J = T _J max.
120°	0.002	0.002	0.002	0.002		
90°	0.003	0.003	0.003	0.003		
60°	0.004	0.004	0.004	0.004		
30°	0.007	0.007	0.007	0.007		

Ordering Information Table

Device Code

SD	250	0	C	25	K
①	②	③	④	⑤	⑥

1 Peak-Reverse Voltage V_{RRM} = V
2 Peak-Forward Current I_{FM} = A
3 Average Current I_{AVG} = A
4 Peak-Reverse Current I_{RM} = A
5 Peak-Forward Voltage V_{FM} = V
6 Peak-Reverse Voltage V_{RRM} = V (see Voltage Rating Table) (K-PUK)

SD2500C..K Series

Bulletin I2089 rev. B 04/00

International
IOR Rectifier

Outline Table

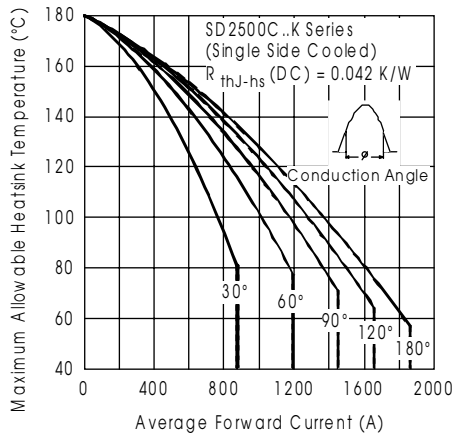
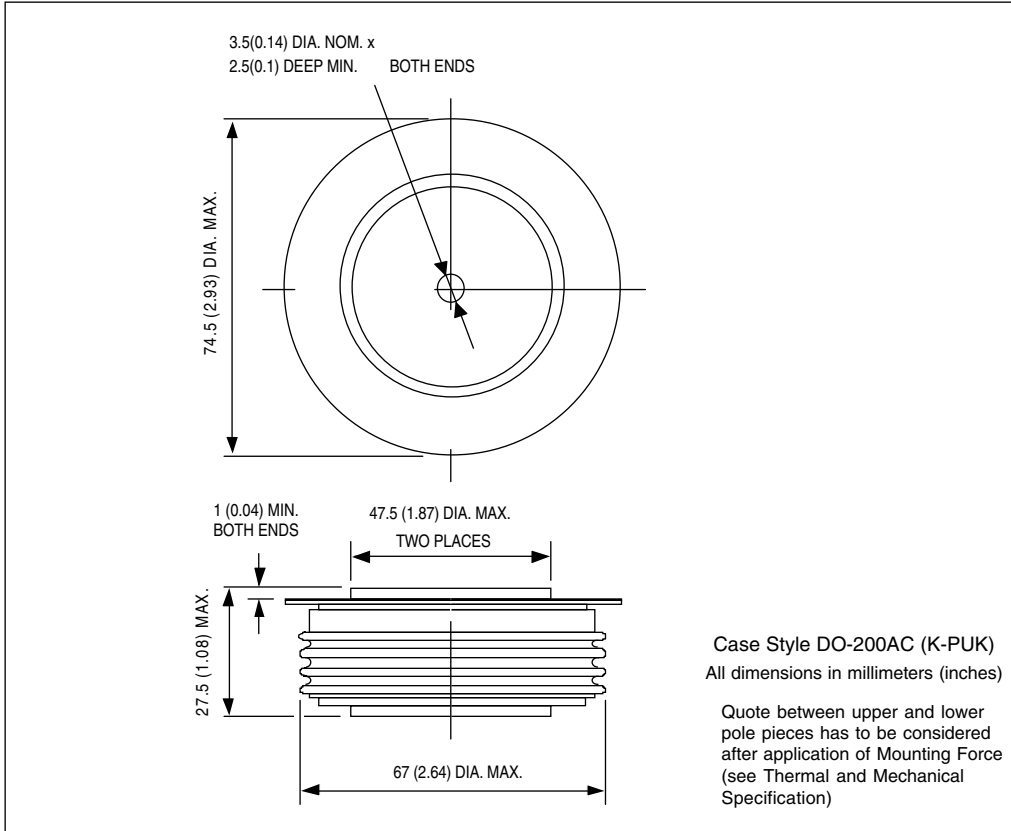

Fig. 1 - Current Ratings Characteristics

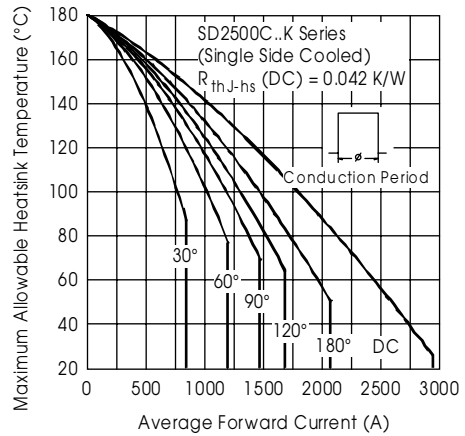

Fig. 2 - Current Ratings Characteristics

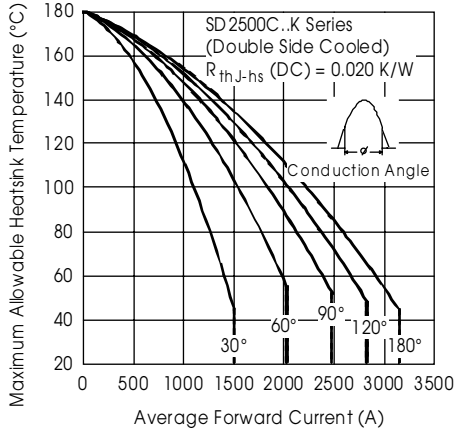

Fig. 3 - Current Ratings Characteristics

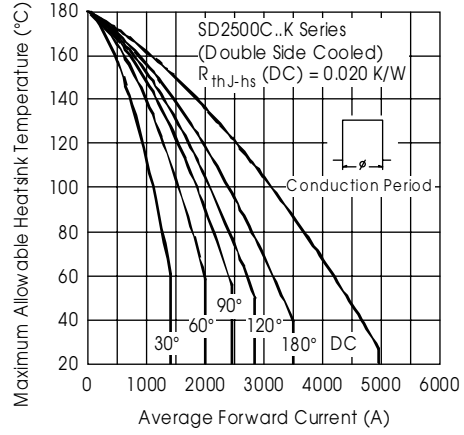

Fig. 4 - Current Ratings Characteristics

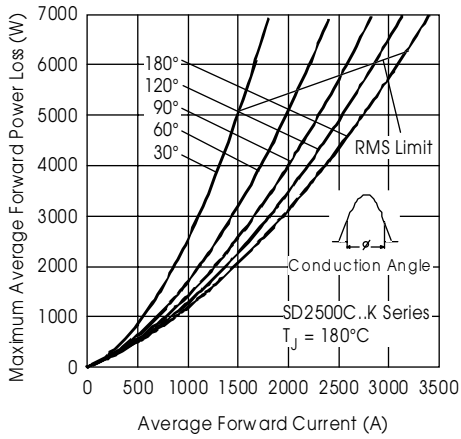

Fig. 5 - Forward Power Loss Characteristics

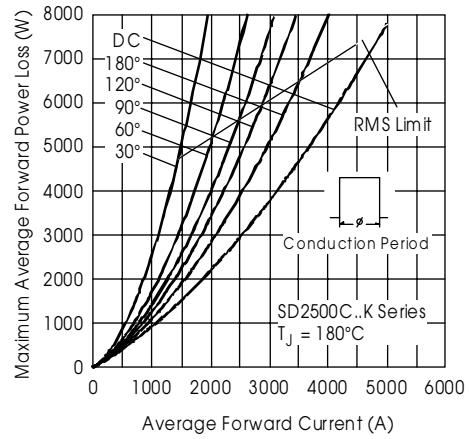

Fig. 6 - Forward Power Loss Characteristics

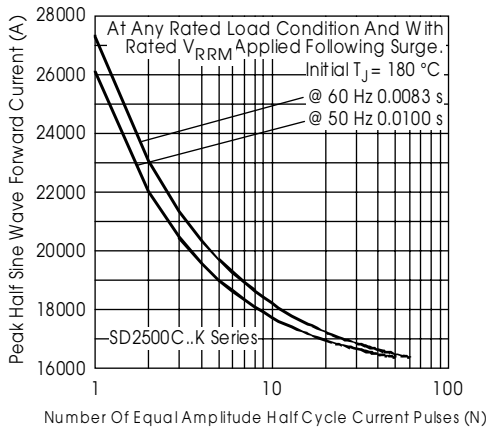

Fig. 7 - Maximum Non-Repetitive Surge Current
 Single and Double Side Cooled

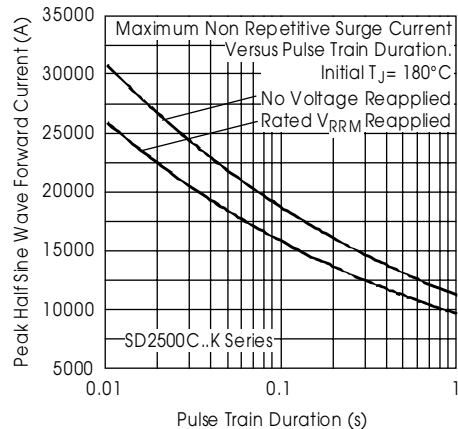

Fig. 8 - Maximum Non-Repetitive Surge Current
 Single and Double Side Cooled

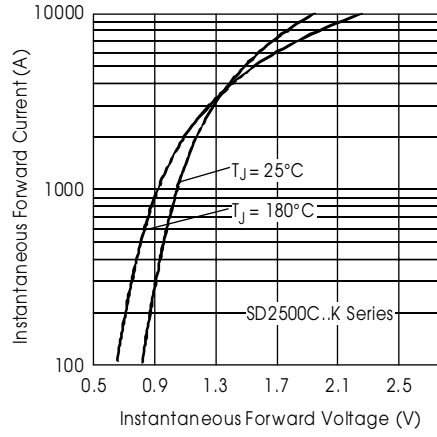

Fig. 9 - Forward Voltage Drop Characteristics

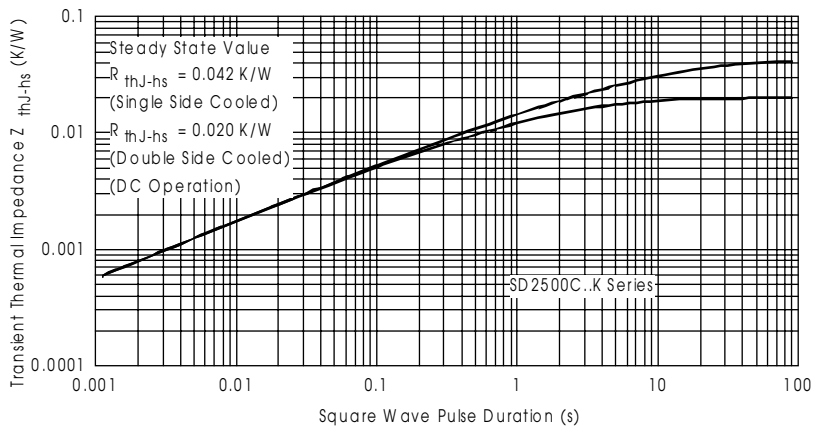

Fig. 10 - Thermal Impedance Z_{thJC} Characteristics



Notice

The products described herein were acquired by Vishay Intertechnology, Inc., as part of its acquisition of International Rectifier's Power Control Systems (PCS) business, which closed in April 2007. Specifications of the products displayed herein are pending review by Vishay and are subject to the terms and conditions shown below.

Specifications of the products displayed herein are subject to change without notice. Vishay Intertechnology, Inc., or anyone on its behalf, assumes no responsibility or liability for any errors or inaccuracies.

Information contained herein is intended to provide a product description only. No license, express or implied, by estoppel or otherwise, to any intellectual property rights is granted by this document. Except as provided in Vishay's terms and conditions of sale for such products, Vishay assumes no liability whatsoever, and disclaims any express or implied warranty, relating to sale and/or use of Vishay products including liability or warranties relating to fitness for a particular purpose, merchantability, or infringement of any patent, copyright, or other intellectual property right.

The products shown herein are not designed for use in medical, life-saving, or life-sustaining applications. Customers using or selling these products for use in such applications do so at their own risk and agree to fully indemnify Vishay for any damages resulting from such improper use or sale.

International Rectifier®, IR®, the IR logo, HEXFET®, HEXSense®, HEXDIP®, DOL®, INTERO®, and POWIRTRAIN® are registered trademarks of International Rectifier Corporation in the U.S. and other countries. All other product names noted herein may be trademarks of their respective owners.