

Operating Instructions

Liquiline

CM442R/CM444R/CM448R

Universal four-wire multichannel controller for cabinet installation

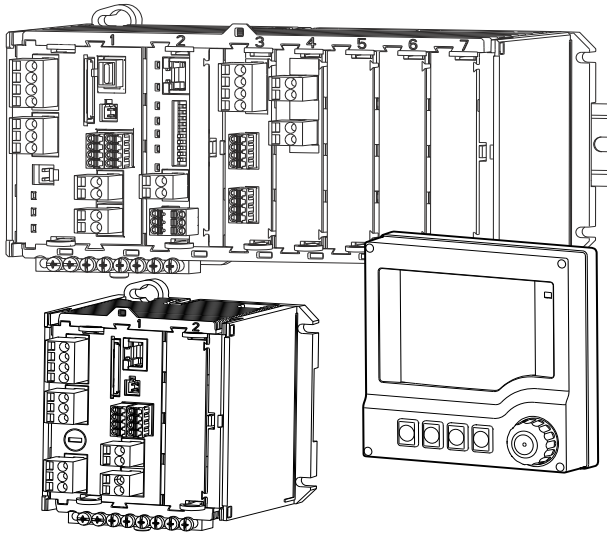

Table of contents

1	Document information	5	8	Operation options	43
1.1	Warnings	5	8.1	Overview	43
1.2	Symbols used	5	8.2	Access to the operating menu via the local display	44
1.3	Documentation	6	8.3	Configuration options	45
2	Basic safety instructions	7	9	Commissioning	48
2.1	Requirements for personnel	7	9.1	Function check	48
2.2	Designated use	7	9.2	Switching on the unit	48
2.3	Occupational safety	8	9.3	Basic setup	50
2.4	Operational safety	8	10	Operation	51
2.5	Product safety	9	10.1	Display	51
3	Device description	10	10.2	General settings	54
3.1	Overview	10	10.3	Current inputs	67
3.2	Device architecture	11	10.4	Outputs	68
4	Incoming acceptance and product identification	13	10.5	Binary inputs and outputs	76
4.1	Incoming acceptance	13	10.6	Additional functions	84
4.2	Product identification	13	11	Diagnostics and troubleshooting	113
4.3	Scope of delivery	14	11.1	General troubleshooting	113
4.4	Certificates and approvals	14	11.2	Diagnostic information on the local display (optional)	114
5	Installation	15	11.3	Diagnostic information via web browser	114
5.1	Installation conditions	15	11.4	Diagnostic information via fieldbus	114
5.2	Mounting the measuring device	18	11.5	Adjusting diagnostic information	115
5.3	Post-installation check	21	11.6	Overview of diagnostic information	118
6	Electrical connection	22	11.7	Pending diagnostic messages	121
6.1	Connection conditions	22	11.8	Diagnostics list	121
6.2	Connecting the measuring device	25	11.9	Event logbook	121
6.3	Connecting the sensors	28	11.10	Simulation	125
6.4	Connecting additional inputs, outputs or relays	31	11.11	Reset measuring instrument	126
6.5	Connecting digital communication	35	11.12	Device information	127
6.6	Hardware settings	37	11.13	Firmware history	129
6.7	Guaranteeing the degree of protection	37	12	Maintenance	130
6.8	Post-connection check	38	12.1	Calibration	130
7	System integration	39	12.2	Cleaning	131
7.1	Web server	39			
7.2	Service interface	41			
7.3	Fieldbuses	42			

- 13 Repair..... 133**
 - 13.1 Spare parts 133
 - 13.2 Return 136
 - 13.3 Disposal 136

- 14 Accessories 137**
 - 14.1 Measuring cable 137
 - 14.2 Sensors 138
 - 14.3 Additional functionality 142
 - 14.4 Software 144
 - 14.5 Other accessories 144

- 15 Technical data 146**
 - 15.1 Input 146
 - 15.2 Digital inputs, passive 147
 - 15.3 Current input, passive 147
 - 15.4 Output 148
 - 15.5 Digital outputs, passive 150
 - 15.6 Current output, active 151
 - 15.7 Relay outputs 152
 - 15.8 Protocol-specific data 153
 - 15.9 Power supply 156
 - 15.10 Performance characteristics 157
 - 15.11 Environment 158
 - 15.12 Mechanical construction 160

- Index 161**

1 Document information

1.1 Warnings

The structure, signal words and safety colors of the signs comply with the specifications of ANSI Z535.6 ("Product safety information in product manuals, instructions and other collateral materials").

Safety message structure	Meaning
<p>⚠ DANGER Causes (/consequences) Consequences of non-compliance (if applicable) ► Corrective action</p>	<p>This symbol alerts you to a dangerous situation . Failure to avoid the situation will result in a fatal or serious injury.</p>
<p>⚠ WARNING Causes (/consequences) Consequences of non-compliance (if applicable) ► Corrective action</p>	<p>This symbol alerts you to a dangerous situation . Failure to avoid the situation can result in a fatal or serious injury.</p>
<p>⚠ CAUTION Causes (/consequences) Consequences of non-compliance (if applicable) ► Corrective action</p>	<p>This symbol alerts you to a dangerous situation . Failure to avoid this situation can result in minor or more serious injuries.</p>
<p>NOTICE Cause/situation Consequences of non-compliance (if applicable) ► Action/note</p>	<p>This symbol alerts you to situations that can result in damage to property and equipment.</p>

1.2 Symbols used



Additional information, tips



Permitted or recommended



Forbidden or not recommended

1.3 Documentation

As a supplement to these Operating Instructions the following manuals are available on the CD-ROM:

- Brief Operating Instructions Liquiline CM44xR, KA01160C
- Operating Instructions Memosens, BA01245C
 - Software description for Memosens inputs
 - Calibration of Memosens sensors
 - Sensor-specific diagnostics and troubleshooting
- Operating Instructions for HART communication, BA00486C
 - Onsite settings and installation instructions for HART
 - Description of HART drivers
- Guidelines for communication via fieldbus and web server
 - HART, SD01187C
 - PROFIBUS, SD01188C
 - Modbus, SD01189C
 - Web server, SD01190C

The CD also contains:

- Technical Information Liquiline CM44xR, TI01112C
- Documentation for other devices in the Liquiline family:
 - Liquiline CM44x (field device)
 - Liquestation CSFxx and Liqueport CSP44 (sampler)
- Simulation software

2 Basic safety instructions

2.1 Requirements for personnel

- ▶ Installation, commissioning, operation and maintenance of the measuring system must only be carried out by specially trained technical personnel.
- ▶ The technical personnel must be authorized for the specified activities by the system operator.
- ▶ Electrical connection must only be carried out by a certified electrician.
- ▶ The technical personnel must have read and understood these Operating Instructions and must adhere to them.
- ▶ Faults at the measuring point may only be rectified by authorized and specially trained personnel.



Repairs that are not described in these Operating Instructions must only be carried out directly at the manufacturer or by the service organization.

2.2 Designated use

2.2.1 Non-hazardous atmosphere

Liquiline CM44xR is a multichannel controller for connecting digital sensors with Memosens technology in non-hazardous environments.

The device is designed for use in the following applications:

- Food and beverages
- Life science
- Water and wastewater
- Chemical industry

2.2.2 Non-designated use and

NOTICE

Objects stored on top of the housing

May cause a short-circuit or fire. Failure of individual cabinet components or complete failure of the measuring point is possible

- ▶ Never place any objects such as tools, cables, paper, food, liquid containers etc. on top of the housing.
- ▶ Always comply with the operator's instructions particularly regarding fire prevention (smoking) and handling foodstuffs (beverages).

Any other use than the one described here compromises the safety of persons and the entire measuring system and is not permitted.

The manufacturer is not liable for damage caused by improper or non-designated use.

2.2.3 Installation environment

The device and the associated power units can be operated with 24 V AC, 24 V DC or 100 to 230 V AC and provide IP20 shock protection. The components have been designed for pollution level 2, and moisture must not be allowed to collect in them. For this reason the components must be installed in an appropriate enclosure for protection. When installing, please observe the ambient conditions specified in the manual.

2.3 Occupational safety

As the user, you are responsible for complying with the following safety conditions:

- Installation instructions
- Local standards and regulations

Electromagnetic compatibility

The product has been tested for electromagnetic compatibility in accordance with the applicable European standards for industrial applications.

The electromagnetic compatibility indicated only applies to a product that has been connected in accordance with the instructions in these Operating Instructions.

2.4 Operational safety

- ▶ Prior to commissioning the entire measuring point, check that all connections are correct. Ensure that electrical cables and hose connections are not damaged.
- ▶ Do not operate damaged products, and secure them against unintentional commissioning. Label and identify the damaged product as being defective.
- ▶ If faults cannot be rectified, the products must be taken out of service and secured against unintentional commissioning.

⚠ CAUTION

The cleaning system is not switched off during calibration or maintenance activities

Risk of injury due to medium or cleaning agent

- ▶ If a cleaning system is connected, switch it off before removing a sensor from the medium.
- ▶ If you are not switching off the cleaning system because you wish to test the cleaning function, wear protective clothing, goggles and gloves or take other appropriate measures.

2.5 Product safety

2.5.1 State of the art

The transmitter is designed to meet state-of-the-art safety requirements, has been tested and left the factory in a condition in which it is safe to operate.

Relevant regulations and European standards have been observed.

2.5.2 IT security

We only provide a warranty if the device is installed and used as described in the Operating Instructions. The device is equipped with security mechanisms to protect it against any inadvertent changes to the device settings.

IT security measures in line with operators' security standards and designed to provide additional protection for the device and device data transfer must be implemented by the operators themselves.

Support in the performance of this task can be requested from Endress+Hauser.

3 Device description

3.1 Overview

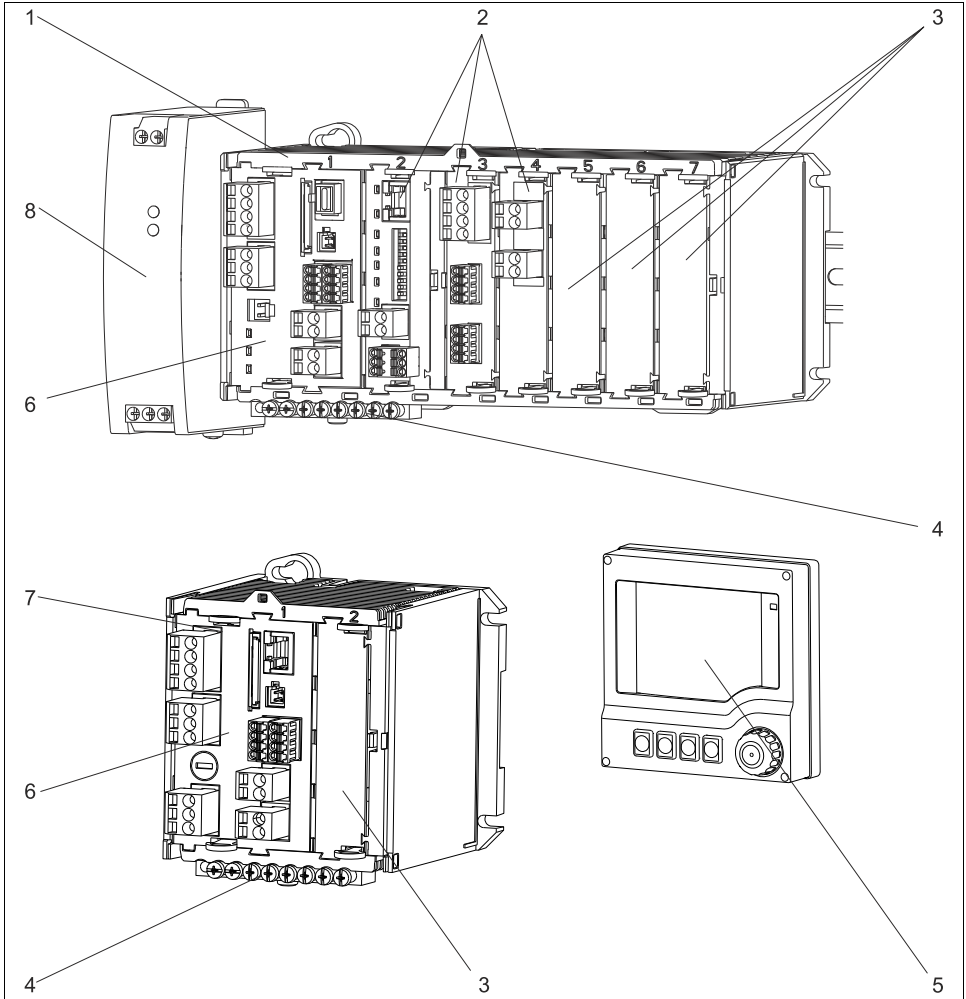

Fig. 1: CM44xR with optional, external display (excluding cables)

a0020573

- | | | | |
|---|--------------------------------|---|---|
| 1 | CM448R ¹⁾ | 5 | External display (optional) |
| 2 | Extension modules (optional) | 6 | Base module |
| 3 | Shock protection, dummy module | 7 | CM442R |
| 4 | Terminal strip | 8 | External power unit (CM444R or CM448R only) |

1) CM444R: same housing, other extension modules

3.2 Device architecture

3.2.1 Slot and port assignment

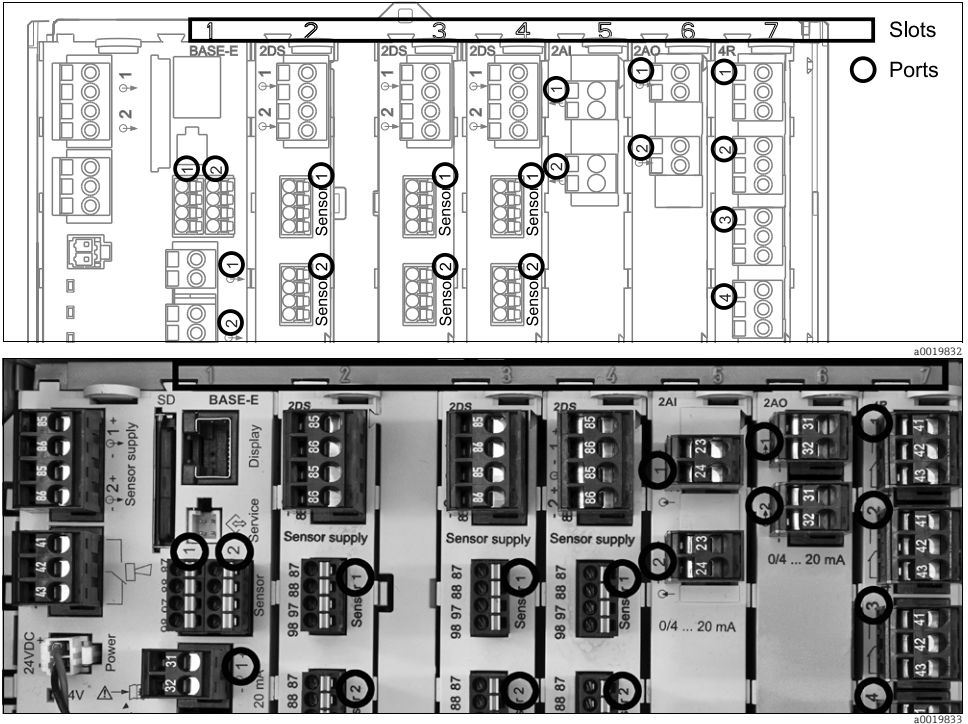

Fig. 2: Slot and port assignment of the hardware modules

Outlet 1	OK
CH1: 1:1 pH Glass ATC 6.95 pH	Port Slot
CH2: 1:2 TU/TS 500.0 g/l	
CH3: 5:1 SAC 500.0 1/m	
CH4: 5:2 Cond i ATC 2.62 mS/cm	
CH5: 6:1 Chlorine 28.33 mg/l	
CH6: 6:2 Redox ± 51 mV	
CH7: 7:1 Oxygen [am... 32.86 mg/l	
CH8: 7:2 Cond c ATC 131.1 µS/cm	
MENU CAL DIAG HOLD	

Fig. 3: Slot and port assignment on the display

- Inputs are assigned to measuring channels in ascending order of the slots and ports.
Adjacent example:
If "CH1: 1:1 pH glass" is displayed, this means:
Channel 1 (CH1) is slot 1 (base module) : port 1 (input 1), pH glass sensor
- The outputs and relays are named after their function, e.g. "Current output", and are displayed with the slot and port numbers in ascending order

3.2.2 Terminal diagram

i The unique terminal name is derived from the following:
Slot No. : Port No. : Terminal

Example, NO contact of a relay:

- Device with 4 inputs for digital sensors, 4 current outputs and 4 relays
- Base module BASE-E (contains 2 sensor inputs, 2 current outputs)
 - Module 2DS (2 sensor inputs)
 - Module 2AO (2 current outputs)
 - Module 4R (4 relays)

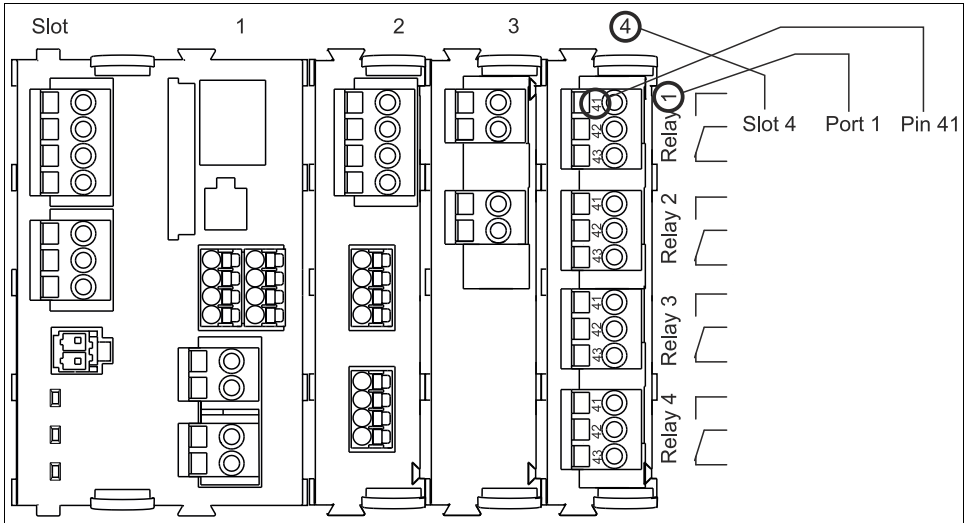

Fig. 4: Creating a terminal diagram taking the example of the NO contact (terminal 41) of a relay

a0015979

4 Incoming acceptance and product identification

4.1 Incoming acceptance

1. Make sure the packaging is undamaged.
 - ↳ Inform the supplier about any damage to the packaging.Keep the damaged packaging until the matter has been settled.
2. Make sure the contents are undamaged.
 - ↳ Inform the supplier about damage to the contents.Keep the damaged products until the matter has been settled.
3. Check that the delivery is complete and nothing is missing.
 - ↳ Compare the scope of delivery against the delivery papers and your order.
4. Pack the product in such a way as to protect it reliably against impact and moisture for storage and transportation.
 - ↳ The original packaging offers the best protection.Keep to the approved ambient conditions (see "Technical data").

If you have any questions, contact your supplier or your local sales center.

4.2 Product identification

4.2.1 Nameplate

Nameplates can be found:

- On the outside of the DIN rail housing
- On the packaging (adhesive label, portrait format)
- On the rear of the external display (covered over when installed)

The nameplate provides you with the following information on your device:

- Manufacturer ID
- Order code
- Extended order code
- Serial number
- Firmware version
- Input and output variables
- Protection class
- Ambient conditions
- Activation codes
- Safety notices and warnings

Compare the data on the nameplate with your order.

4.2.2 Identifying the product

The order code and serial number of your device can be found in the following locations:

- On the nameplate
- In the delivery papers

 To find out the version of your device, enter the order code indicated on the nameplate in the search screen at the following address:
www.products.endress.com/order-ident

4.3 Scope of delivery

- 1 controller in the version ordered
- 1 external display (optional)
- 1 DIN rail power unit incl. cable (only CM444R and CM448R)
- 1 printed copy of Operating Instructions for DIN rail power unit
- 1 CD with Operating Instructions
- 1 printed copy of the Brief Operating Instructions in the language ordered

If you have any questions, contact your supplier or your local sales center.

4.4 Certificates and approvals

4.4.1 CE mark: Declaration of Conformity

With this declaration, the manufacturer guarantees that the product conforms to the regulations of European Directive 2004/108/EC concerning electromagnetic compatibility and Low Voltage Directive 2006/95/EC. This is proven by observing the standards listed in the Declaration of Conformity.

4.4.2 cCSAus

Application has been submitted

5 Installation

5.1 Installation conditions

5.1.1 DIN rail mounting

⚠ CAUTION

Power unit can become very hot when operating at full load

Danger of burns

- ▶ Avoid touching the power unit when it is in operation.
- ▶ The required minimum distances from other devices must be strictly observed.
- ▶ Once you have switched off the power unit, wait until it has cooled down before carrying out any work on it.

⚠ CAUTION

Unpermitted moisture in the device

Puts the user's safety at risk

- ▶ The device has shock protection in accordance with IP20. Moisture must not be allowed to collect in the device.
- ▶ Observe the specified ambient conditions e.g. by installing in an appropriate enclosure.

NOTICE

Incorrect mounting location in control cabinet, distances not observed

Possible functional failures due to heat buildup, interference from neighboring devices

- ▶ Do not place the device directly above heat sources. The temperature specifications must be strictly observed.
- ▶ The components are designed for cooling through convection. Avoid heat buildup and ensure that openings are not covered e.g. by cables lying on top of them.
- ▶ Observe the specified distances from other devices.
- ▶ Keep the device physically separate from frequency converters and high-voltage devices.
- ▶ Recommended installation direction: horizontal. The specified ambient conditions, in particular the ambient temperatures, apply here only.
- ▶ A vertical orientation is possible. However, in this case, additional fixing clips are required at the place of installation to keep the device in position on the DIN rail.
- ▶ Recommended installation of power unit for CM444R and CM448R: to the left of the device.

The following minimum distances must be observed:

- Laterally from other devices incl. power units and from wall of cabinet:
at least 20 mm (0.79 inch)
- above, below, in front of and behind the device (from cabinet door or other devices installed there):
at least 50 mm (0.79 inch)

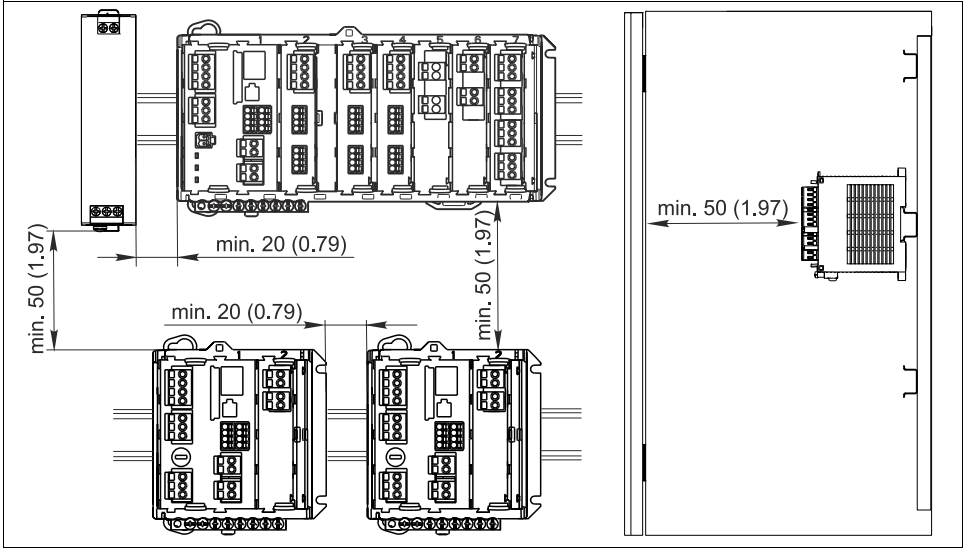

a0020564

Fig. 5: Minimum distances in mm (inch)

5.1.2 Cable length for optional display

The length of the display cable delivered with the kit is 3 m (10 ft). The maximum permitted is 5 m (16 ft).

5.1.3 Wall mounting

Using eyelets and slotted holes on housing

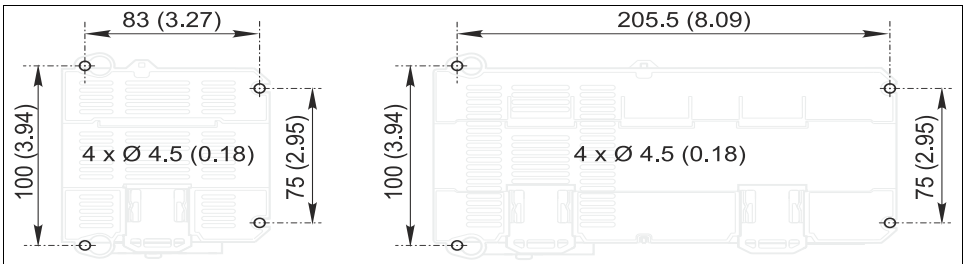

a0020541

Fig. 6: Hole pattern for wall mounting in mm (inch)

5.1.4 External display

- i** The mounting plate is also used as the drill template. The markings on the side serve as a guide when marking the position for the drill holes.

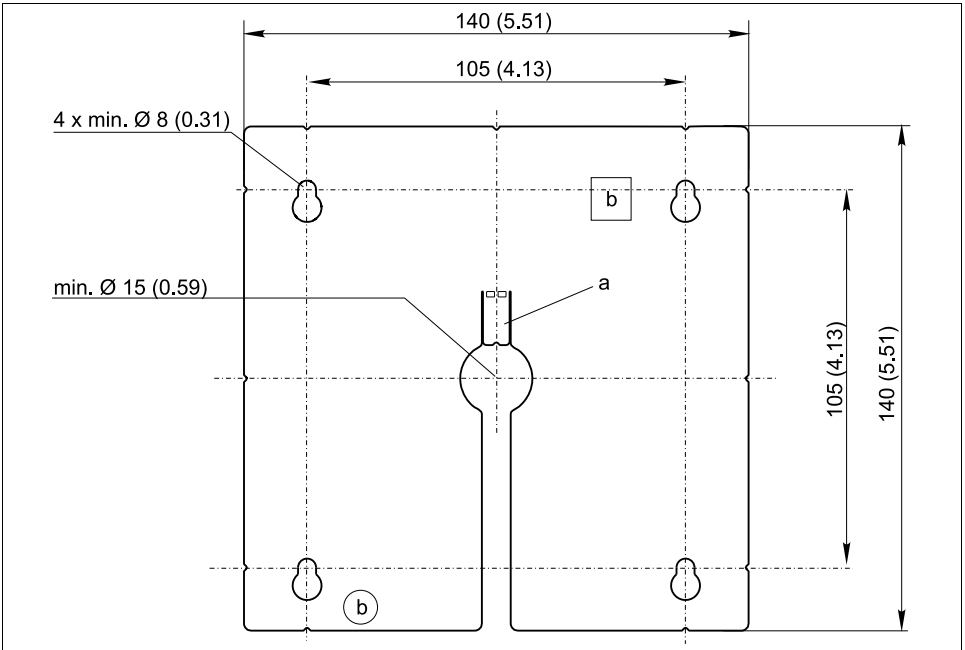

a0019718

Fig. 7: Mounting plate for external display in mm (inch)

- a* Retaining tab
b Production-related cut-outs, no function for user

5.2 Mounting the measuring device

5.2.1 DIN rail mounting

The mounting procedure is the same for all devices. The example shows a CM448R. In the order configuration, the securing clips are "tightened" to secure the DIN rail.

1. Release the securing clips by pulling them downwards.

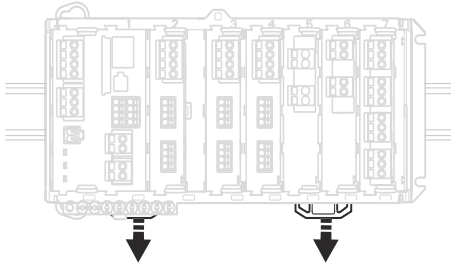

2. Attach the device from the top to the DIN rail (a) and then press it down to secure it (b).

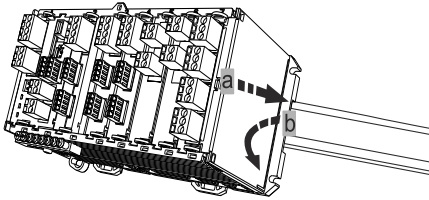

3. Slide the securing clips upwards until they click, thereby securing the device to the DIN rail.

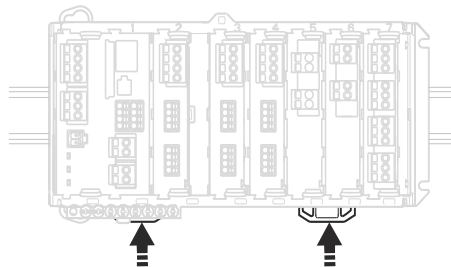

Only CM444R and CM448R

4. Mount the external power unit in the same way.

5.2.2 Wall mounting

- i** Mounting material (screws, dowels) are not included in the scope of delivery and must be provided by the customer.

CM444R and CM448R: The external power unit can only be mounted on a DIN rail.

Use the back of the housing to mark the mounting holes (→  6).

1. Drill the required holes and place dowels in them if necessary.
2. Screw the housing onto the wall.

5.2.3 Mounting the optional external display

⚠ CAUTION

Sharp-edged, non-deburred drill holes

Risk of injury, display cable may get damaged

- ▶ In particular, deburr the central drill hole for the display cable.

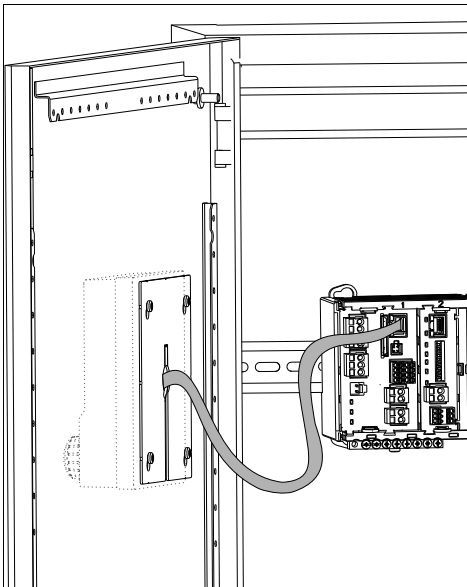

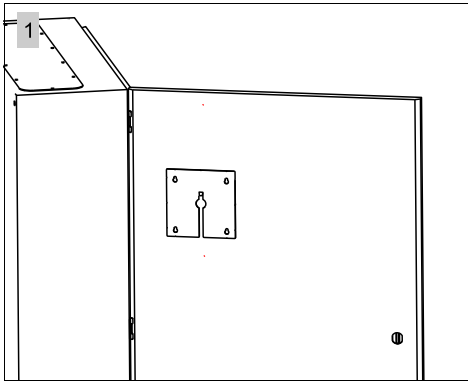

Fig. 8: Fully mounted display

Mounting the display on the door of the cabinet

To do this, use the mounting plate as a drill template. In addition, you will need a pen to mark the drill holes, as well as a serrated edge rule and a drill.

1. Hold the mounting plate from the outside against the door of the control cabinet. Choose the point at which you wish to install the display.
2. Make all the markings.
3. Draw lines connecting the markings.
 - ↳ This will indicate the position of the five drill holes needed.
4. Drill the holes (→  7).
5. Pull the display cable through the hole in the middle, and place the display from the outside through the 4 holes drilled for this purpose, ensuring that the torx screws have been unscrewed to the last half turn but are still in place.
6. Connect the display cable to the RJ-45 socket in the base module.
7. Place the mounting plate (a) on the inside over the screws, slide it down (b) and tighten the screws (c).
 - ↳ The display is now mounted and ready to use.



a0019871

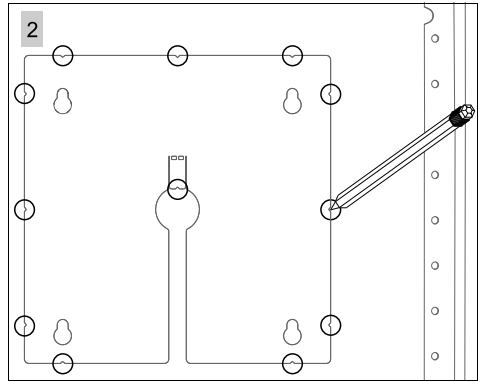

a0019872

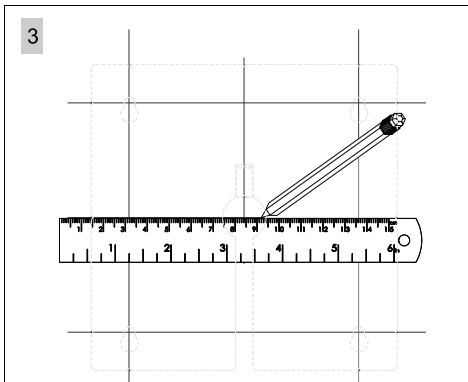

a0019873

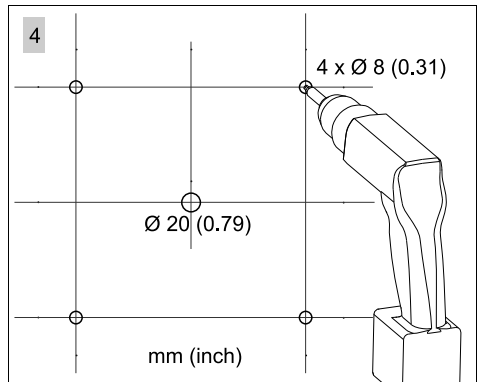

a0019874

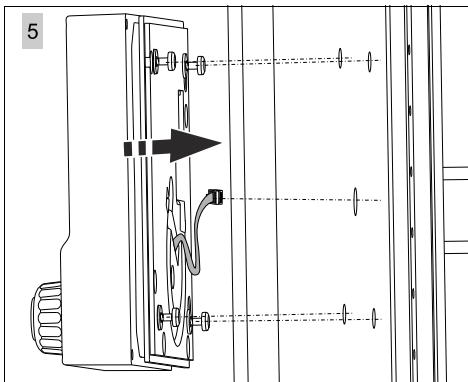

a0019903

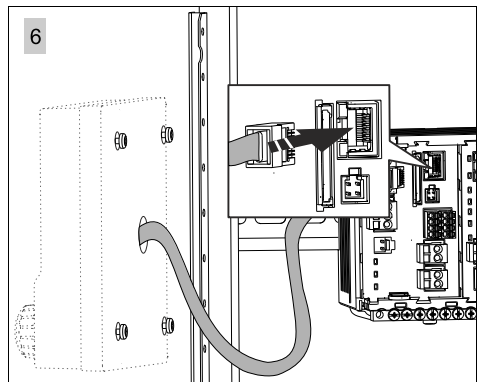

a0019881

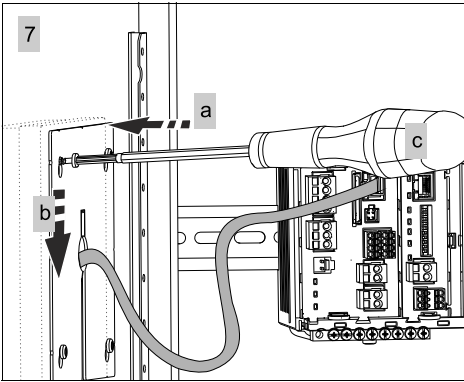

a0019880

NOTICE**Installation errors**

Damage e.g. to the cable, or malfunctions

- ▶ Lay the cables in such a way that they cannot get squashed e.g. when closing the cabinet door.
- ▶ Verify that you have actually put the display cable into the RJ45 socket in the base module and not, for example, into the Ethernet socket of the (optional) module 485. Otherwise, your display will not function.

5.3 Post-installation check

1. Following installation, check all devices (controller, power unit, display) for damage.
2. Verify that the specified mounting distances have been observed.
3. Verify that all securing clips have been snapped into place and that the components are securely positioned on the DIN rail.
4. Ensure that the temperature limits at the mounting location are observed.

6 Electrical connection

⚠ WARNING

The device is live!

Incorrect wiring can result in injury or fatality

- ▶ The electrical connection may only be established by an electrical technician.
- ▶ The electrical technician must have read and understood these Operating Instructions and must follow the instructions they contain.
- ▶ **Prior to beginning** any wiring work, make sure voltage is not applied to any of the cables.

NOTICE

Faulty cable run

Cable damage due to absence of strain relief, faults on signal lines

- ▶ Run all cables through the cable channels of the cabinet to the terminals.
- ▶ Run the signal cables to the terminals separately from the live cables.

6.1 Connection conditions

6.1.1 Remote operation via HART (e.g. via HART modem and FieldCare)

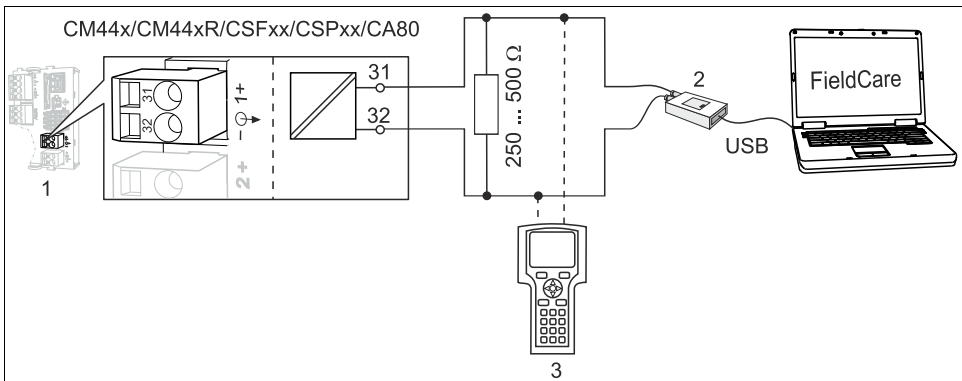

Fig. 9: HART via modem

a0015608

- 1 Base-L, -H or -E device module: current output 1 with HART
- 2 HART modem for connecting to PC, e.g. FXA195¹⁾
- 3 HART handheld terminal

- 1) Switch set to "on" (substitutes the resistor)

6.1.2 Remote operation via PROFIBUS DP

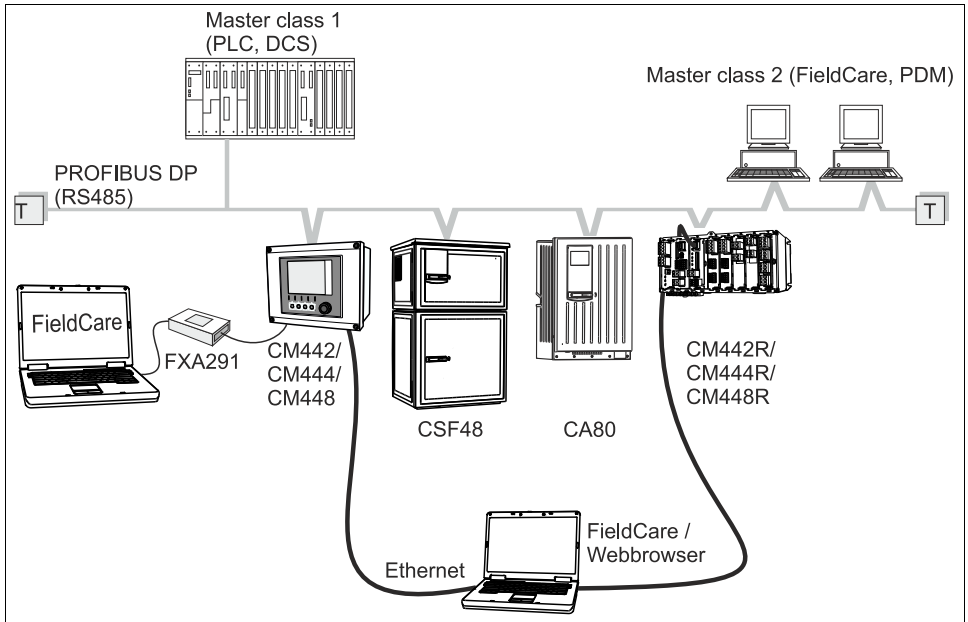

Fig. 10: PROFIBUS DP

T Terminating resistor

a0015874

6.1.3 Remote operation via Modbus RS485

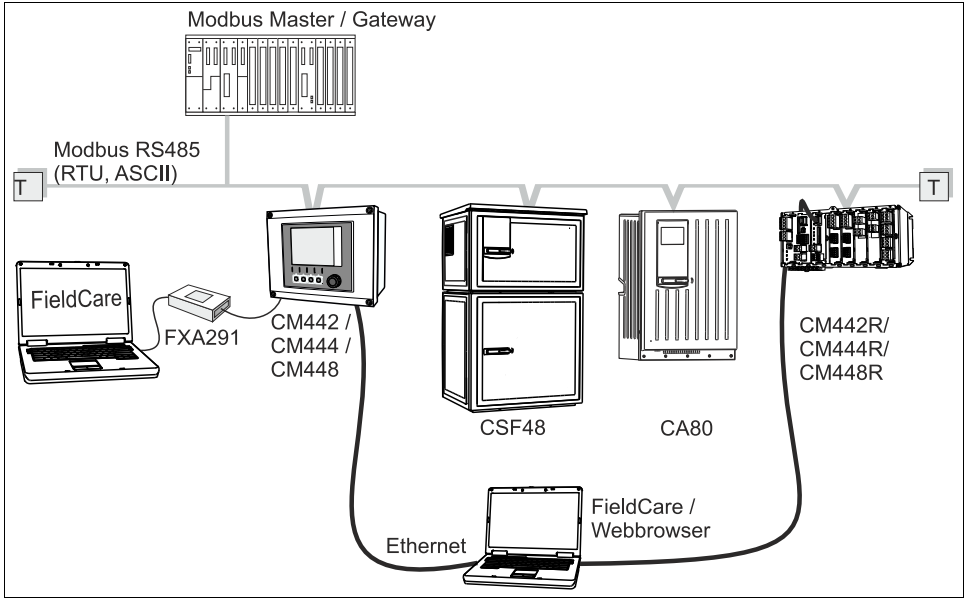

Fig. 11: Modbus RS485

a0015875

T Terminating resistor

6.1.4 Remote operation via ethernet/Web server/Modbus TCP/EtherNet/IP

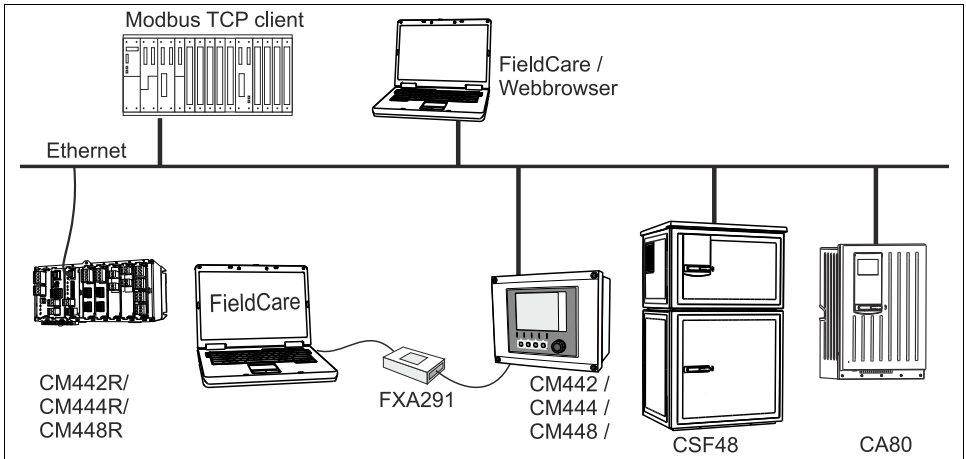

Fig. 12: Modbus TCP and / or ethernet

a0015876

6.2 Connecting the measuring device

⚠ WARNING

The device is live!

Incorrect wiring can result in injury or fatality

- ▶ **Prior to beginning** any wiring work, make sure voltage is not applied to any of the cables.

NOTICE

The device does not have a power switch

- ▶ At the installation location, you must provide a protected circuit breaker in the vicinity of the device.
- ▶ The circuit breaker must be a switch or a power-circuit breaker and must be labeled as the circuit breaker for the device.
- ▶ At the supply point, the power supply for the 24 V versions must be isolated from dangerous live cables by double or reinforced insulation.

6.2.1 Cable terminals

Plug-in terminals for Memosens and PROFIBUS/RS485 connections

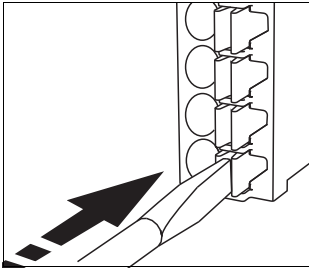

a0012691

Fig. 13: Press the screwdriver against the clip (opens the terminal)

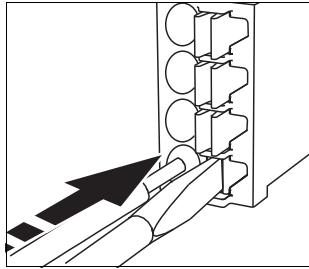

a0012692

Fig. 14: Insert the cable until the limit stop

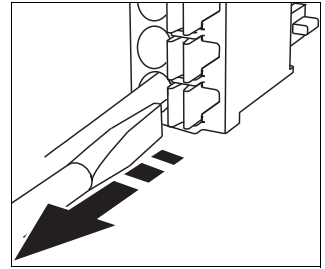

a0012693

Fig. 15: Remove the screwdriver (closes the terminal)

- i** After connection, make sure that every cable end is securely in place. Terminated cable ends, in particular, tend to come loose easily if they have not been correctly inserted as far as possible.

All other plug-in terminals

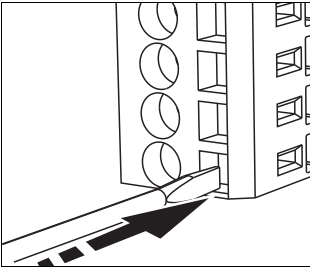

Fig. 16: Insert the screwdriver until the limit stop (opens the terminal)

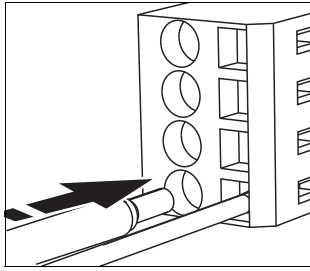

Fig. 17: Insert the cable until the limit stop

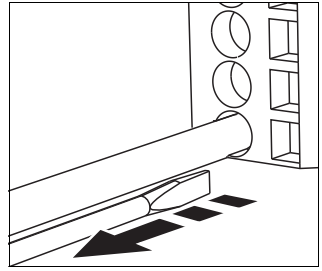

Fig. 18: Remove the screwdriver (closes the terminal)

6.2.2 Power supply CM442R

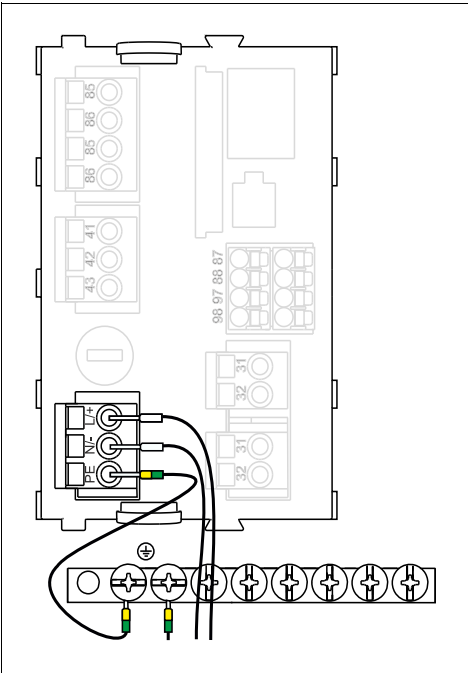

Fig. 19: Power supply connection on BASE-H or -L

- H Power unit 100 to 230 VAC
- L Power unit 24 VAC or 24 VDC

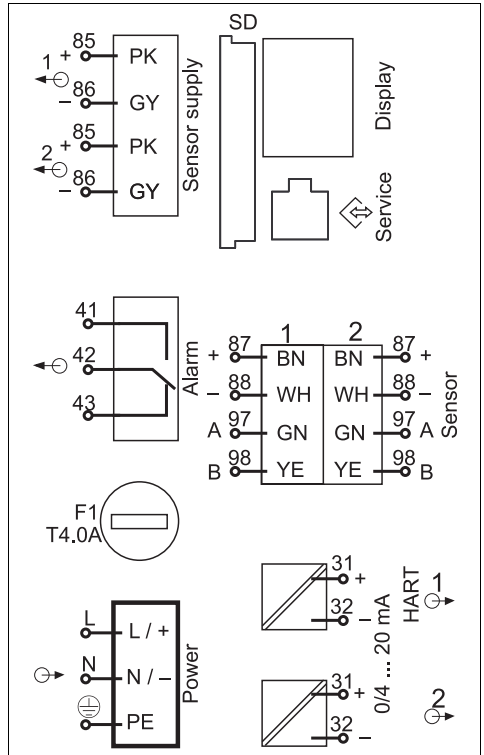

Fig. 20: Overall wiring diagram BASE-H or -L

NOTICE

Incorrect connection and cable run not separate

Interference on signal or display cable, incorrect measured values or failure of display may occur

- ▶ Do not connect the cable shield of the display cable to PE (terminal strip of device)!
- ▶ Run the signal/display cable in the control cabinet separately from live cables.

6.2.3 Power supply CM444R and CM448R

i Both device versions must be operated exclusively using the power unit provided, including its cable. Please also pay attention to the enclosed Operating Instructions for the power unit.

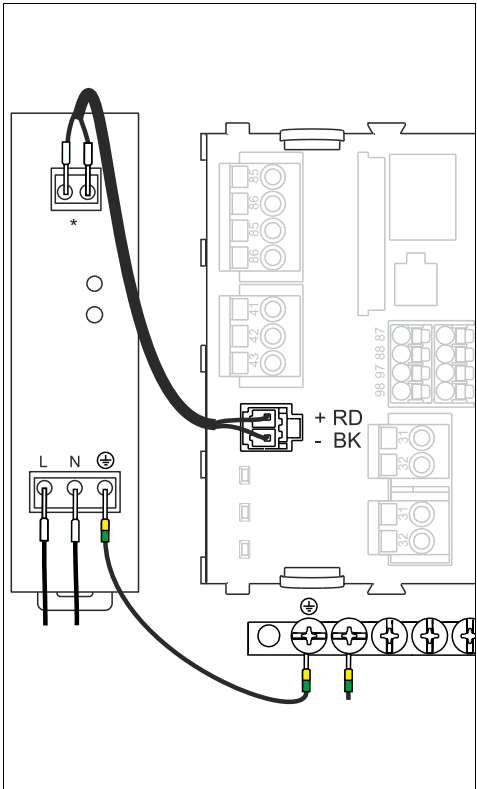

Fig. 21: Power supply connection with BASE-E
 * Assignment depending on power unit, ensure that the connection is correct

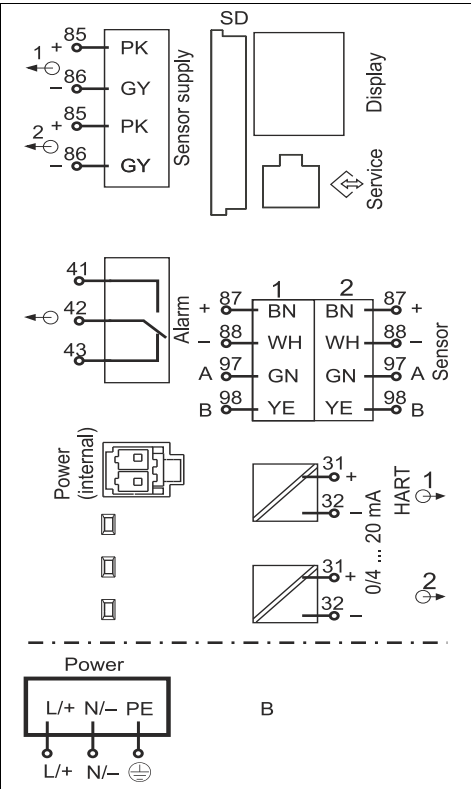

Fig. 22: Overall wiring diagram BASE-E
 B External power unit

NOTICE**Incorrect connection and cable run not separate**

Interference on signal or display cable, incorrect measured values or failure of display may occur

- ▶ Do not connect the cable shield of the display cable to PE (terminal strip of device)!
- ▶ Run the signal/display cable in the control cabinet separately from live cables.

6.3 Connecting the sensors

6.3.1 Sensor types with Memosens protocol

Sensor types	Sensor cable	Sensors
Digital sensors without additional internal power supply	CYK10 with plug connection and inductive signal transmission	<ul style="list-style-type: none"> ▪ pH sensors ▪ ORP sensors ▪ Combined sensors ▪ Amperometric oxygen sensors ▪ Conductive conductivity sensors ▪ Chlorine sensors
	Fixed cable	Inductive conductivity sensors
Digital sensors with additional internal power supply	Fixed cable	<ul style="list-style-type: none"> ▪ Turbidity sensors ▪ Sensors for interface measurement ▪ Sensors for measuring the spectral absorption coefficient (SAC) ▪ Nitrate sensors ▪ Optical oxygen sensors ▪ Ion-sensitive sensors

The following rule applies if connecting CUS71D sensors:

- CM442R
 - Only one CUS71D is possible; an additional sensor is not allowed.
 - The second sensor input may also not be used for another type of sensor.
- CM444R
 - No restrictions. All the sensor inputs can be used as required.
- CM448R
 - If a CUS71D is connected, the number of sensor inputs that can be used is limited to a maximum of 4.
 - Of these, all 4 inputs can be used for CUS71D sensors.
 - Every combination of CUS71D and other sensors is possible provided that the total number of connected sensors does not exceed 4.

6.3.2 Functional ground connection

You must always connect the terminal strip with PE from the central node in the cabinet.

Use the conductor with cable clamp that is included with the Memosens cable to connect the functional ground to the terminal strip of the CM44xR.

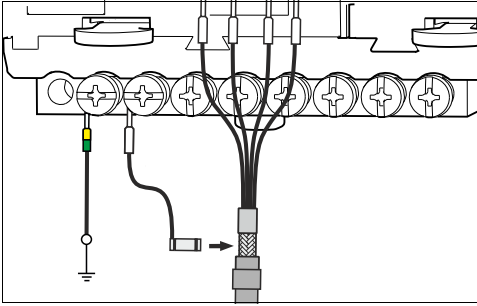

a0020579

Fig. 23: Functional ground connection



You must only ever connect one functional ground to each screw in the terminal strip. Otherwise, shielding is not guaranteed.

6.3.3 Connecting sensors with Memosens protocol

Connection methods

1. Sensor cable directly connected to the terminal connector of the sensor module 2DS or the L, H or E base module

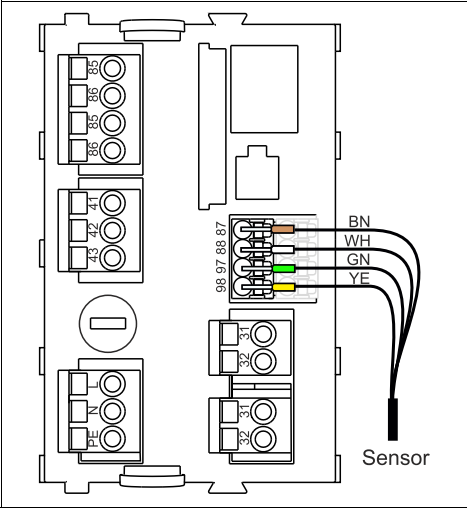

Fig. 24: Sensors without additional supply voltage

a0012459

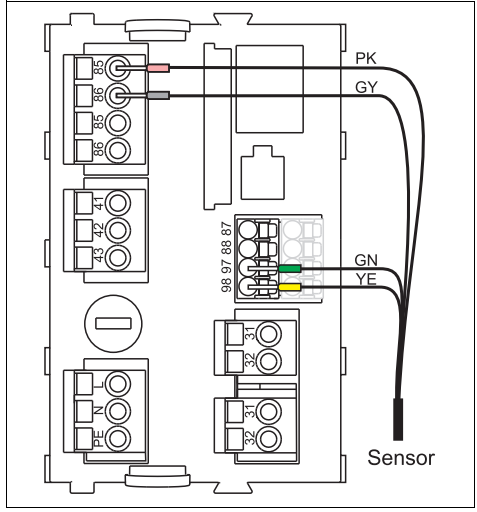

Fig. 25: Sensors with additional supply voltage

a0012460

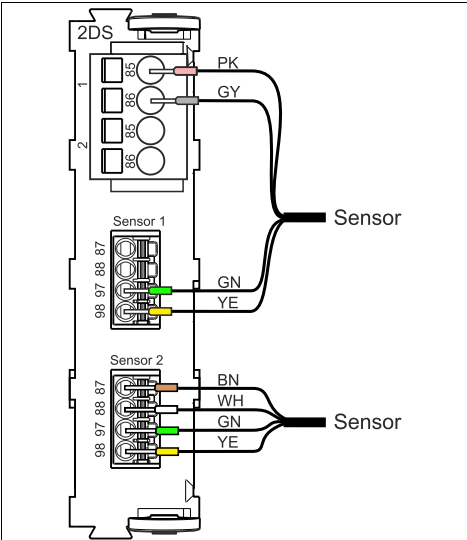

Fig. 26: Sensors with and without additional supply voltage at sensor module 2DS



a0016197

6.4 Connecting additional inputs, outputs or relays

⚠ WARNING

Module not covered

No shock protection. Danger of electric shock!

- ▶ If you are modifying or extending your hardware, always fill the slots from left to right. Do not leave any gaps.
 - ▶ If not all the slots are occupied, always insert one or more dummy modules into the slot to the right of the last module until all the positions are filled (→  1, item 3). This ensures the unit is shock-protected.
 - ▶ Always ensure shock protection is guaranteed particularly in the case of relay modules (2R, 4R, AOR).
-  The terminal strip (→  23) is used to connect cable shields. Any shields that are additionally needed must be connected to PE centrally in the cabinet via terminal blocks provided by the customer.

6.4.1 Digital inputs and outputs

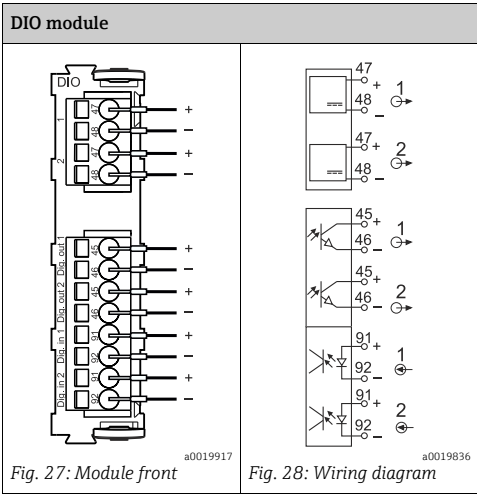
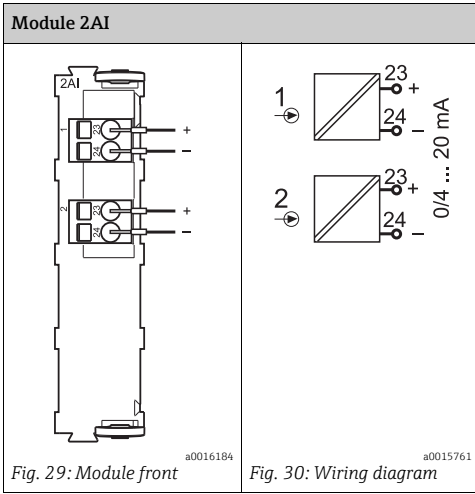

Fig. 27: Module front

Fig. 28: Wiring diagram

6.4.2 Current inputs



6.4.3 Current outputs

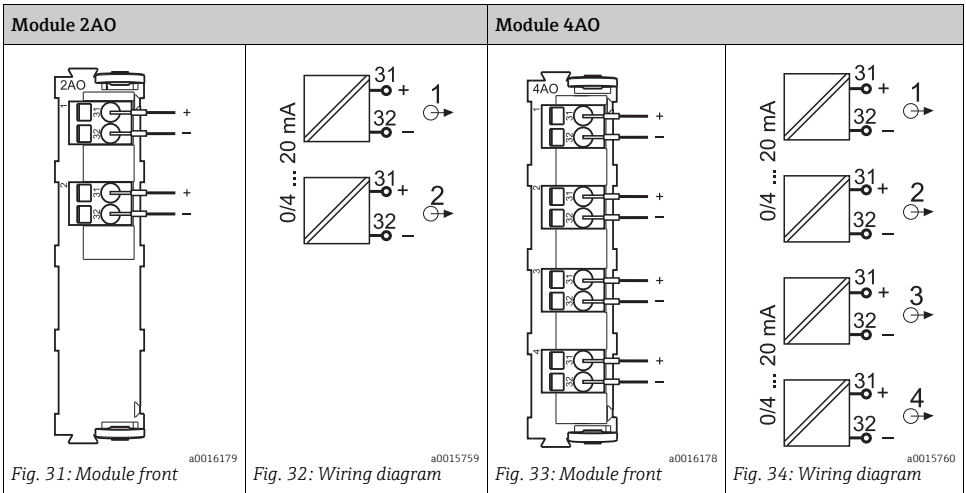

6.4.4 Relays

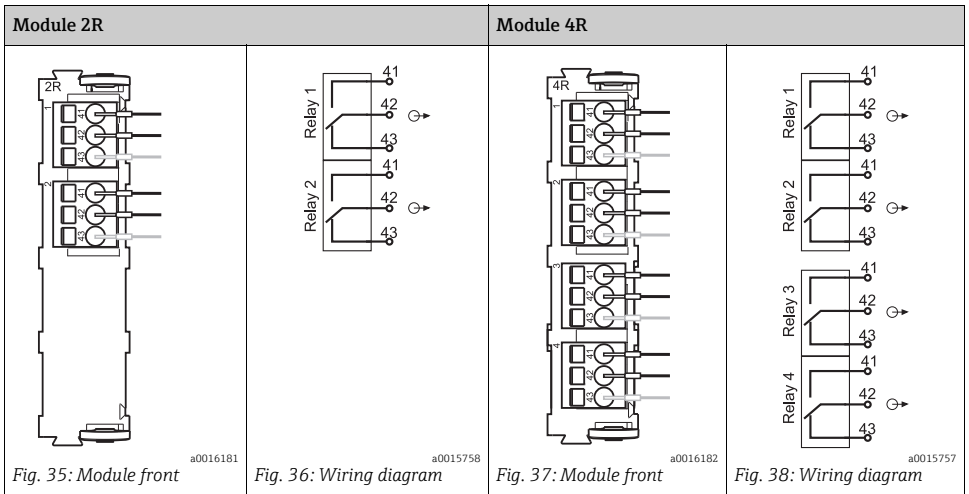

Example: Connecting the cleaning unit 71072583 for CAS40D

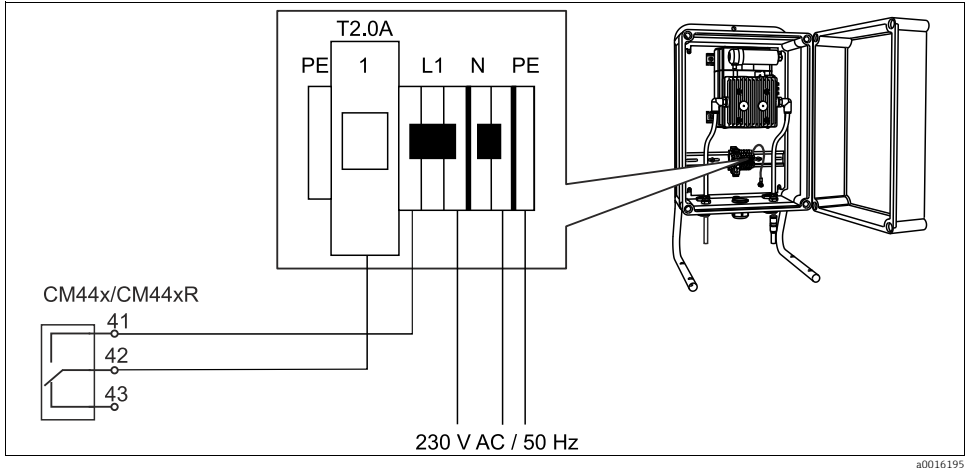
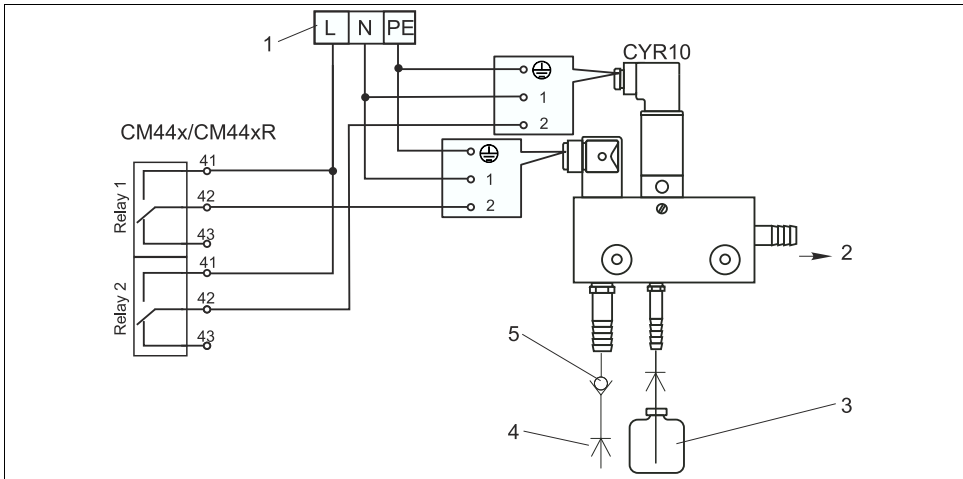

Fig. 39: Connecting the cleaning unit for CAS40D

Example: Connecting the injector cleaning unit Chemoclean CYR10

a0016194

Fig. 40: Connecting the injector cleaning unit CYR10

- 1 External power supply
- 2 Cleaner to spray head
- 3 Container with cleaner
- 4 Motive water 2 to 12 bar (30 to 180 psi)
- 5 Backflow valve (to be provided by the customer)

6.5 Connecting digital communication

6.5.1 Module 485

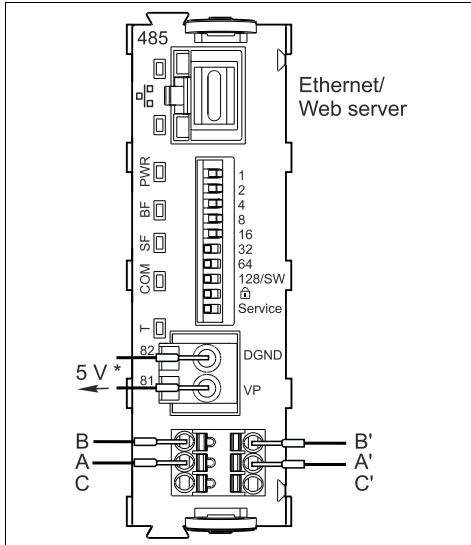

a0016173

Fig. 41: Bus connections on module 485

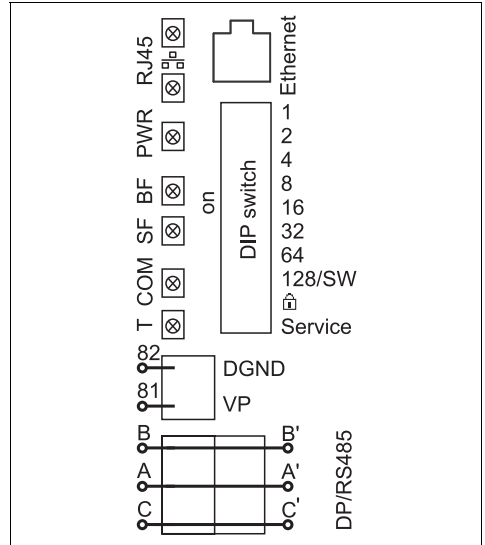

a0015762

Fig. 42: Wiring diagram for module 485

* Optional to supply power to an external terminating resistor for bus termination

LEDs on front of module

LED	Designation	Color	Description
RJ45	LNK/ACT	GN	<ul style="list-style-type: none"> Off = Connection is not active On = Connection is active Flashing = Data transmission
RJ45	10/100	YE	<ul style="list-style-type: none"> Off = Transmission rate 10 MBit/s On = Transmission rate 100 MBit/s
PWR	Power	GN	Supply voltage is applied and module is initialized
BF	Bus failure	RD	Bus failure
SF	System failure	RD	System failure
COM	Communication	YE	Sending or receiving Modbus message
T	Bus termination	YE	<ul style="list-style-type: none"> Off = No termination On = Termination is used

DIP switches on front of module

DIP	Factory setting	Assignment
1-128	ON	Bus address (--> "Commissioning/Communication")
	OFF	Write protection: "ON" = configuration not possible via the bus, only via local operation
Service	OFF	Only for service, not to be used by the operator

6.5.2 Bus termination

There are two ways to terminate the bus:

1. **Internal terminating resistor** (via DIP switch on the module board)

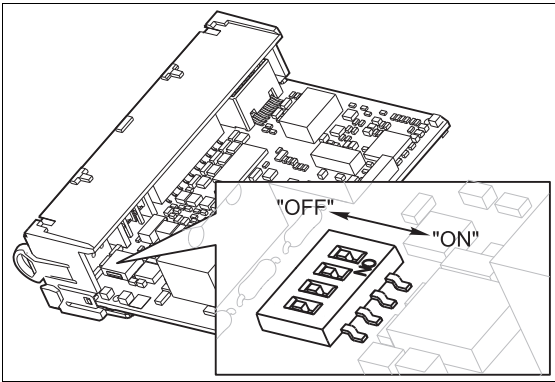

Fig. 43: DIP switches for internal terminating resistor

- ▶ Using a suitable tool, such as a tweezers, set all 4 DIP switches to the "ON" position.
 - ↳ The internal terminating resistor is used.

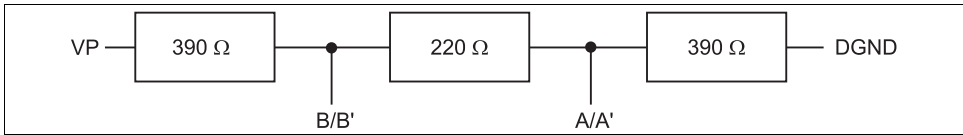

Fig. 44: Structure of the internal terminating resistor

a0016306

2. **External terminating resistor**

Here, leave the DIP switches on the module board in the "OFF" position (factory setting).

- ▶ Connect the resistor to terminals 81 and 82 on the front of module 485 for 5-V power supply.
 - ↳ The external terminating resistor is used.

6.6 Hardware settings

Setting the bus address

- ▶ Set the desired bus address via the DIP switches of module 485.

i For PROFIBUS DP, valid bus addresses are anything between 1 and 126, and anything between 1 and 247 for Modbus. If you configure an invalid address, software addressing is automatically enabled via the local configuration or via the fieldbus.

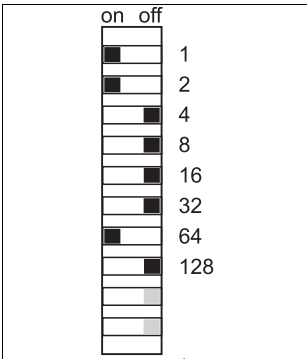

a0016322

Fig. 45: Valid PROFIBUS address 67

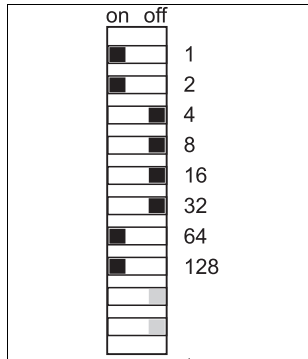

a0016323

Fig. 46: Valid Modbus address 195

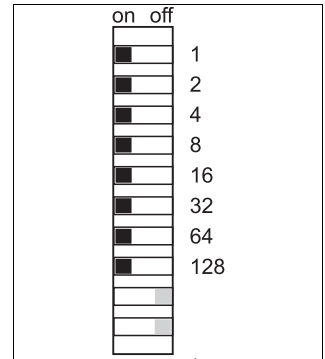

a0016324

Fig. 47: Invalid address 255 ¹⁾

- 1) Order configuration, software addressing is enabled, software address configured at the factory: PROFIBUS 126, Modbus 247

6.7 Guaranteeing the degree of protection

Only the mechanical and electrical connections that are described in this manual, and are necessary for the required, designated application, may be established on the device supplied.

- ▶ Please pay close attention when performing the work as degrees of protection individually confirmed for this product (ingress protection (IP), electrical safety, EMC interference immunity, explosion protection) can no longer be guaranteed as a result of things such as:
 - Leaving off covers
 - Using power units other than those supplied with the device
 - Modules that are not fully secured
 - Display not fully secured (risk of moisture entering due to inadequate sealing)
 - Loose or insufficiently tightened cables/cable ends

6.8 Post-connection check

▲ WARNING

Wiring errors

Incorrect wiring puts the safety of people and the measuring point at risk. The manufacturer does not accept any responsibility for errors that result from failure to comply with the instructions in this manual.

► Operate the device only if you can answer **yes to all** of the following questions.

Electrical connection

- Are the mounted cables strain relieved?
- Are the cables run without loops and cross-overs?
- Are the signal lines correctly connected in accordance with the wiring diagram?
- Are all plug-in terminals securely engaged?
- Are all the connection wires securely positioned in the cable terminals?

7 System integration

7.1 Web server

7.1.1 Connection

- ▶ Connect the PC communication cable to the RJ45 port of module 485.

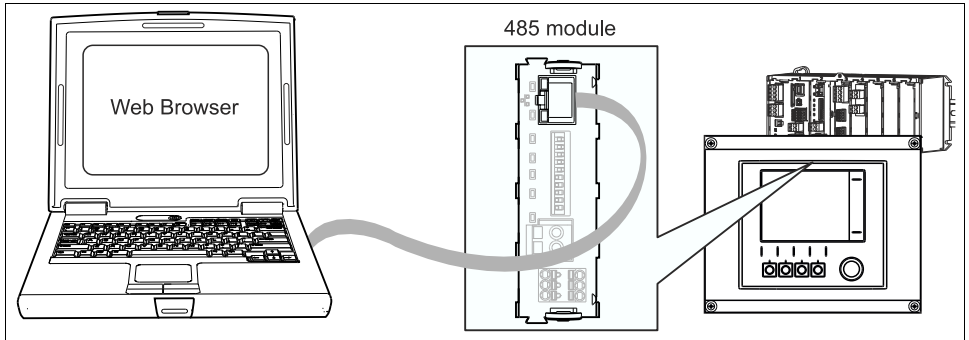

Fig. 48: Ethernet connection

a0016228

7.1.2 Creating the data connection

1. Start your PC.
2. First, set a manual IP address in the network connection settings of the operating system.
 - ↳ This address must be in the same subnetwork as the IP address of the device.

Example:

- IP address for the PC: 192.168.1.213

3. Start the Internet browser.

If you use a proxy server to connect to the Internet:

4. Disable the proxy (browser settings under "Connections/LAN settings").
5. Enter the IP address of your device in the address line.

↳ The system takes a few moments to establish the connection and then the CM44 web server starts.

- ▶ Enter the following address(es) to download logbooks:
 - 192.168.1.212/logbooks_csv.fhtml (for logbooks in CSV format)
 - 192.168.1.212/logbooks_fdm.fhtml (for logbooks in FDM format)

- i** Downloads in FDM format can be securely transmitted, saved and visualized with Endress+Hauser's "Field Data Manager Software".
 (--> www.products.endress.com/ms20)

7.1.3 Operation

The menu structure of the web server corresponds to the onsite operation.

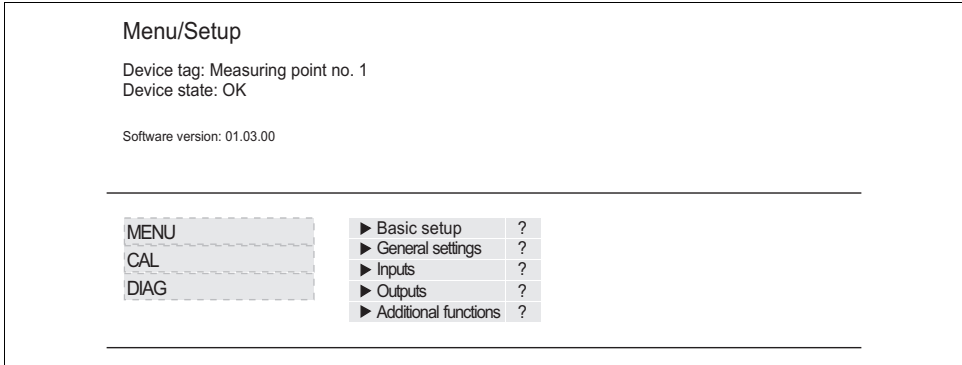

Fig. 49: Example of web server (menu/language=English)

a0016397

- Clicking a menu name or a function corresponds to pressing the navigator.
- You can make your settings conveniently via the computer keyboard.

- i** Instead of using an Internet browser, you can also use FieldCare for configuration via ethernet. The ethernet DTM required for this purpose can be downloaded from the product page.

7.2 Service interface

You can connect the device to a computer via the service interface and configure it using "Fieldcare". Furthermore, configurations can also be saved, transferred and documented.

7.2.1 Connection

- ▶ Connect the service connector to the interface on the Liquiline base module and connect it to the Commubox.
- ▶ Via the USB port, connect the Commubox to the computer running the Fieldcare software.

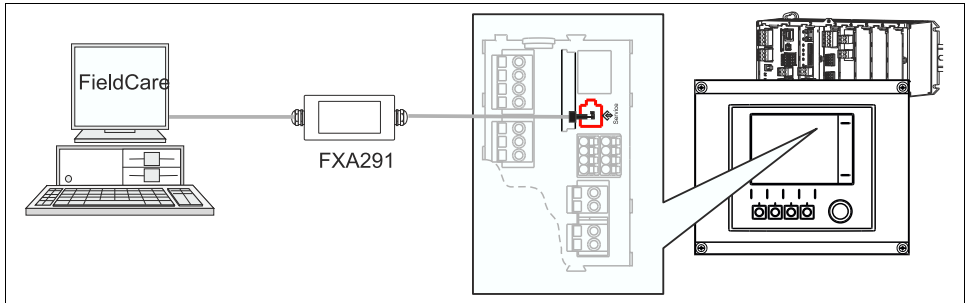

Fig. 50: Connection overview

a0014953

7.2.2 Creating the data connection

1. Start Fieldcare.
2. Establish a connection to the Commubox. For this, select the ComDTM "CDI Communication FXA291"
3. Then select the DTM for CM442/CM444/CM448/CM442R/CM444R/CM448R and start the configuration.

You can now start online configuration via the DTM.

Online configuration competes with onsite operation, i.e. each of the two options blocks the other one. On both sides it is possible to take away access from the other side.

i A video showing an example of how to set up a connection to CM44x is available on the CD.

7.2.3 Operation

- In the DTM the menu structure corresponds to the onsite operation. The functions of the Liquiline soft keys are found in the main window on the left.
- Clicking a menu name or a function corresponds to pressing the navigator.
- You can make your settings conveniently via the computer keyboard.
- Via Fieldcare, you can save logbooks, make backups of configurations and transfer the configurations to other devices.
- You can also print out configurations or save them as PDFs.

7.3 Fieldbuses

7.3.1 HART

You can communicate using the HART protocol via current output 1.

- ▶ Connect the HART modem or handheld to current output 1 (communication load 230 - 500 Ohm).
- ▶ Establish the connection via your HART device.

 All the information on HART communication is provided on the CD (--> BA00486C).

7.3.2 PROFIBUS DP

With the fieldbus module 485 and the appropriate device version, you can communicate via PROFIBUS DP.

Connect the PROFIBUS data cable to the terminals of the fieldbus module as described →  35.

7.3.3 Modbus

With the fieldbus module 485 and the appropriate device version, you can communicate via Modbus RS485 or Modbus TCP.

The RTU and ASCII protocols are available when connecting via Modbus RS485. You can switch to ASCII on the device.

Connect the Modbus data cable to the terminals of the fieldbus module (RS 485) or to the RJ45 (TCP) port as described (→  35).

7.3.4 EtherNet/IP

With the fieldbus module 485 and the appropriate device version, you can communicate via EtherNet/IP.

Connect the EtherNet/IP data cable to the RJ45 socket of the fieldbus module as described.

8 Operation options

8.1 Overview

8.1.1 Display and operating elements (only with optional display)

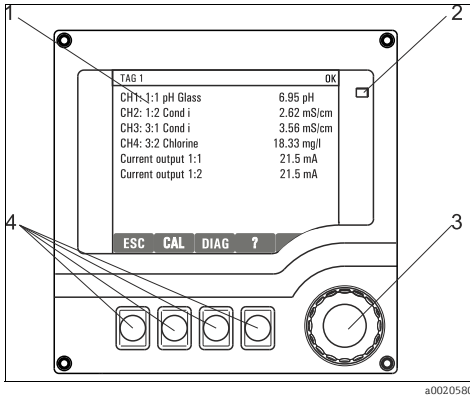

a0020580

Fig. 51: Overview of operation

- 1 Display (lights up red in the event of an error)
- 2 LED
- 3 Navigator (jog/shuttle and press/hold function)
- 4 Soft keys (function depends on the menu)

8.1.2 Display

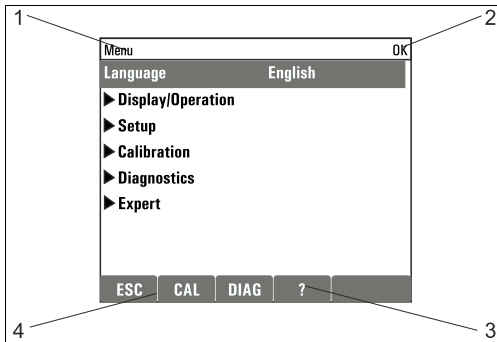

a0012697-en

Fig. 52: Display (example)

- 1 Menu path and/or device designation
- 2 Status display
- 3 Help if available
- 4 Assignment of the soft keys

8.2 Access to the operating menu via the local display

8.2.1 Operating concept (with optional display)

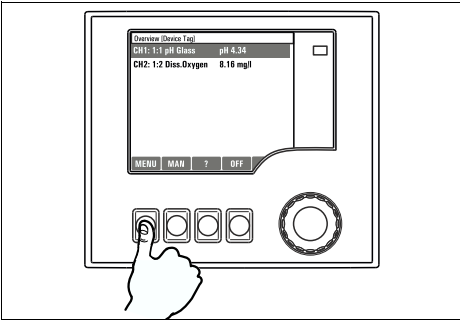

Fig. 53: Pressing the soft key: selecting the menu directly

a0013353-en

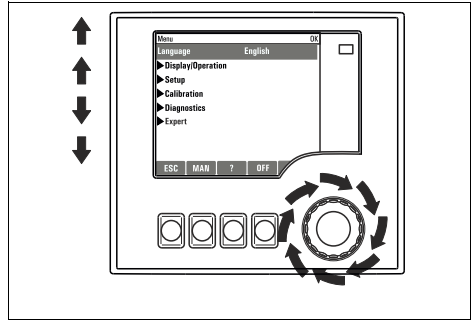

Fig. 54: Turning the navigator: moving the cursor in the menu

a0013354-en

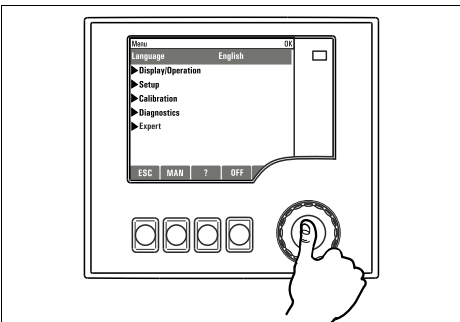

Fig. 55: Pressing the navigator: launching a function

a0013355-en

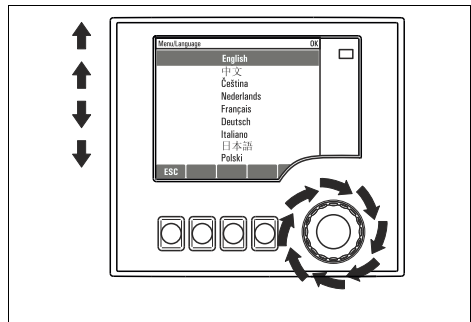

Fig. 56: Turning the navigator: selecting a value (e.g. from a list)

a0013356-en

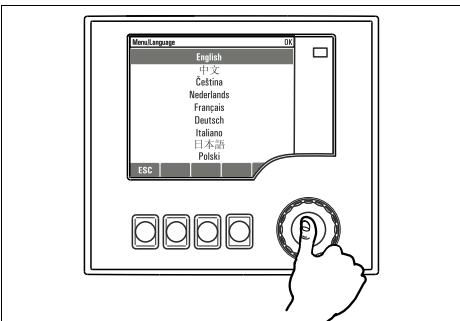

Fig. 57: Pressing the navigator: accepting the new value

a0013357-en

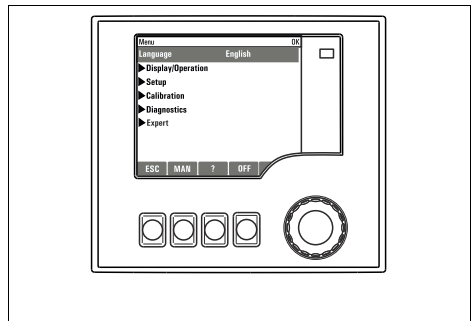

Fig. 58: Result: new setting is accepted

a0013358-en

8.2.2 Locking or unlocking operating keys

Locking operating keys

1. Press the navigator for longer than 2 s.

↳ A context menu for locking the operating keys is displayed.

You have the choice of locking the keys with or without password protection. "With password" means that you can only unlock the keys again by entering the correct password. You can set this password here: Menu/Setup/General settings/Extended setup/Data management/Change lock password.

2. Choose whether you want to lock with or without a password.

↳ The keys are locked. No more entries can be made. In the soft key bar you can see the symbol .

-  The password is 0000 when the device is delivered from the factory. **Make sure to note down any new password** as otherwise you will not be able to unlock the keypad yourself.

Unlocking operating keys

1. Press the navigator for longer than 2 s.

↳ A context menu for unlocking the operating keys is displayed.

2. Select "Key unlock".

↳ The keys are unlocked immediately if you did not choose to lock with a password. Otherwise you are asked to enter your password.

3. Only if keypad is password-protected: enter the right password.

↳ The keys are unlocked. It is possible to access the entire onsite operation again. The symbol  is no longer visible on the screen.

8.3 Configuration options

8.3.1 Display only

- You can only read the values but cannot change them.
- Typical read-only values are: sensor data and system information
- Example: Menu/Setup/Inputs/.../Sensor type

8.3.2 Picklists

- You receive a list of options.
- You select one of the options.
- Example: Menu/Setup/General settings/Temperature unit

8.3.3 Numerical values

- You are changing a variable.
- The maximum and minimum values for this variable are shown in the editor.
- Set a value within this range.
- Example: Menu/Display/Operation/Contrast

Menu/Display/Operation/Contrast		OK	
52			
Min	5	0	1
Max	95	2	3
		4	5
		6	7
		8	9
		←	C
		X	✓
X		←	✓

8.3.4 Actions

- You trigger an action with the appropriate function.
- You know that the item in question is an action if it is preceded by the following symbol: ▷

8.3.5 Free text

- You are assigning an individual designation.
- Enter a text. You can use the characters in the editor for this purpose (upper-case and lower-case letters, numbers and special characters).
- Using the soft keys, you can:
 - Cancel your entries without saving the data (X)
 - Delete the character in front of the cursor (X)
 - Move the cursor back one position (←)
 - Finish your entries and save (✓).

8.3.6 Tables

- Tables are needed to map mathematical functions.
- You edit a table by navigating through rows and columns with the navigator and changing the values of the cells.
- You only edit the numerical values. The controller automatically takes care of the engineering units.
- You can add rows to the table (soft key "INSERT") or delete them (soft key "DEL").
- Afterwards, you save the table (soft key "SAVE").
- You can also cancel your entries any time via the soft key **X**.
- Example: Menu/Setup/Inputs/pH/Medium comp.

Menu/.../Inputs/pH/Medium comp.		OK
	Temperature	pH
1	20.0 °C	pH 6.90
2	25.0 °C	pH 7.00
3	30.0 °C	pH 7.10

X	INSERT	DEL	SAVE	
----------	--------	-----	------	--

9 Commissioning

9.1 Function check

⚠ WARNING

Incorrect connection, incorrect supply voltage

Safety risks for staff and device malfunctions

- ▶ Check that all connections have been established correctly in accordance with the wiring diagram.
- ▶ Make sure that the supply voltage matches the voltage indicated on the nameplate.

9.2 Switching on the unit

i During the device startup phase, the relay and current outputs have an undefined status for a few seconds prior to initialization.

Watch out for possible effects on any actuators which may be connected.

9.2.1 Setting the operating language

Setting the language, configuring the display

If you have not already done so, close the housing cover and screw the device closed.

1. Switch on the supply voltage.
 - ↳ Wait for the initialization to complete.
2. Press the soft key for "MENU". Select your language in the top menu item.
3. Go to the "Display/Operation" menu and configure your desired display settings (Contrast, Backlight and Screen rotation).
 - ↳ You have now changed the display to suit your requirements and can operate the device in the preferred language.

9.2.2 Display settings

Path: Menu/Display/Operation

Function	Options	Info
Contrast	5 to 95 % Factory setting 50 %	Adjust the screen settings to suit your working environment. Backlight="Automatic" The backlighting is switched off automatically after a short time if a button is not pressed. It switches back on again as soon as you press the navigator button.
Backlight	Options <ul style="list-style-type: none"> ▪ On ▪ Off ▪ Automatic Factory setting Automatic	Backlight="On" The backlighting does not switch off automatically.

Path: Menu/Display/Operation

Function	Options	Info
Screen rotation	Options <ul style="list-style-type: none"> ■ Manual ■ Automatic Factory setting Manual	If "Automatic" is selected, the single-channel measured value display switches from one channel to the next every second.
▶ User definable screens		
▶ Meas. screen 1 to ▶ Meas. screen 6		You can create 6 measuring screens of your own and give them a name. As the functions are the same for all 6 measuring screens, only one measuring screen is described below.
Meas. screen	Options <ul style="list-style-type: none"> ■ Off ■ On Factory setting Off	Once you have defined your own measuring screen, you can switch it on here. You can find the new screen under "User definable screens" in the "All measured values" measuring mode.
Label	Customized text, 20 characters	Name of the measuring screen Appears in the status bar of the display.
Number of lines	1 to 8 Factory setting 1	Specify the number of measured values displayed.
▶ Line 1 to ▶ Line 8		As the following functions are the same for all the lines, they are only described once.
Signal type	Options <ul style="list-style-type: none"> ■ Source of data ■ Output Factory setting Source of data	Select a source of data or an output as the signal type.
Source of data <i>Signal type= "Source of data"</i>	Options <ul style="list-style-type: none"> ■ None ■ Sensor inputs ■ Controller ■ Current inputs ■ Fieldbus signals ■ Mathematical functions Factory setting None	Select a data source. You can choose from connected sensors, available controllers, current inputs, fieldbus signals and mathematical functions.
Output <i>Signal type= "Output"</i>	Options <ul style="list-style-type: none"> ■ None ■ Binary outputs ■ Current outputs ■ Relays Factory setting None	Select an output. You can choose from binary outputs, current outputs and relays.

Path: Menu/Display/Operation

Function	Options	Info
Measured value	Options <ul style="list-style-type: none"> ■ Depends on the source of data or output Factory setting None	You can display different measured values depending on the source of data or output.
Label	Customized text, 20 characters	User-defined name for the parameter to be displayed
▷ Set label to "%0V" ¹⁾	Action	If you perform this action you accept the parameter name that is automatically suggested. Your own parameter name ("Label") is lost!

- 1) "%0V" here stands for text that depends on the context. This text is generated automatically by the software and inserted in place of %0V. In the simplest situations, the generated text could be the name of the measuring channel, for example.

9.3 Basic setup

Making basic settings

1. Go to the "Setup/Basic setup" menu.

Make the following settings:

2. Device tag: Give your device any name of your choice (max. 32 characters).
3. Set date: Correct the set date if necessary.
4. Set time: Correct the set time if necessary.

For quick commissioning, you can ignore the additional settings for outputs , relays etc. You can make these settings later in the specific menus.

5. Return to the measuring mode, by pressing and holding the soft key for "ESC" for at least one second.
 - ↳ Your controller now works with your general settings. The sensors connected use the factory settings of the sensor type in question and the individual calibration settings that were last saved.

If you want to configure your most important input and output parameters already in the "Basic setup", proceed as follows:

- ▶ Configure the current outputs, relays, limit contactors, controllers, device diagnostics and cleaning cycles with the submenus which follow the time setting.

10 Operation

10.1 Display

10.1.1 Soft keys in the measurement mode

On the bottom row of the display you can find four soft keys in the measuring screens:

- "MENU", "CAL" and "DIAG" take you directly to the particular software menu.
- With "HOLD" you can activate an immediate, general hold for sensors. This interrupts any sensor cleaning programs that are currently running. However, you can also start manual sensor cleaning when a hold is active.

10.1.2 Measuring mode

There are various display modes:

(Press the navigator button to change the mode)

1. Overview of all the inputs and outputs
2. Main measured value of an input or output or the status of a relay
3. Main and secondary measured value of a sensor input
4. All measured values of a sensor input
5. User-defined measuring screens

You configure the type and number of values you want to display. You can choose from all the measured values of physical and "virtual" sensors (calculated using mathematical functions) and output parameters.





 In modes 2-4, you can switch between channels by turning the navigator.

Sensor type	Main value	Main / secondary measured value	All values
pH, glass	pH value	pH value, temperature	Main value, Raw value, Temperature, Glass Impedance
Combined sensor pH and ORP	pH value or ORP or rH value	pH value or ORP or rH value, temperature	Main value, Raw value, Temperature, Glass Impedance
pH, ISFET	pH value	pH value, temperature	Main value, Raw value, Temperature
ORP	ORP	ORP, temperature	Main value, Raw value, Offset, Temperature
Conductivity, measured inductively	Conductivity	Conductivity, temperature	Main value, Raw value, Temperature
Conductivity, measured conductively	Conductivity	Conductivity, temperature	Main value, Raw value, Temperature
Oxygen, optical and amperometric	Dissolved oxygen	Dissolved oxygen, temperature	Partial pressure, Saturation, Concentration, Temperature

Sensor type	Main value	Main / secondary measured value	All values
Chlorine, amperometric	Chlorine	Chlorine, temperature	Main value, Raw value, Temperature
Nitrate	Nitrate	Nitrate, temperature	Main value, Raw value, Temperature
Spectral absorption coefficient (SAC)	SAC	SAC, temperature	Main value, Raw value, Temperature
Sludge level	Turbidity	Turbidity, temperature	Main value, Raw value, Temperature
Ammonium, ion-sensitive	Ammonium	Ammonium, temperature	Main value, Raw value, Temperature
Nitrate, ion-sensitive	Nitrate	Nitrate, temperature	Main value, Raw value, Temperature
Potassium, ion-sensitive	Potassium	Potassium, temperature	Main value, Raw value, Temperature
Interface measurement	UIS	UIS	UIS, turbidity also: graphic display

10.1.3 Device status

Icons on the display alert you to special device states.

Icon	Location	Description
F	Title bar	Diagnostic message "Failure"
M	Title bar	Diagnostic message "Maintenance request"
C	Title bar	Diagnostic message "Check"
S	Title bar	Diagnostic message "Out of specification"
	Title bar	Fieldbus or TCP/IP communication active
	Title bar	Hold active
	At measured value	Hold for the actuator (current output, limit contactor etc.) is active
	At measured value ¹⁾	An offset has been added to the measured value
	At measured value	Measured value in "Bad" or "Alarm" state
ATC	At measured value	Automatic temperature compensation active
MTC	At measured value	Manual temperature compensation active
SIM	Title bar	Simulation mode active or Memocheck SIM connected

Icon	Location	Description
SIM	At measured value	The measured value is influenced by a simulated value
SIM	At measured value	The displayed measured value is simulated

1) Only pH or ORP measurement

 If two or more diagnostics messages occur simultaneously, only the icon for the message with the highest priority is shown on the display (for the order of priority according to NAMUR, see the "Changing diagnostic information" section).

10.1.4 Assignment views

Assignment views, e.g. Channel assignment view, appear as the last function in many sections of the menu.

You can use this function to see which actuators or functions are connected to an or a sensor channel.

The assignments appear in hierarchical order.

10.2 General settings

10.2.1 Basic settings

Path: Menu/Setup/General settings

Function	Options	Info
Device tag	Customized text, 32 characters	Select any name for your controller. Use the TAG name for example.
Temperature unit	Options <ul style="list-style-type: none"> ■ °C ■ °F ■ K Factory setting °C	
Current output range	Options <ul style="list-style-type: none"> ■ 0 to 20 mA ■ 4 to 20 mA Factory setting 4 to 20 mA	In accordance with Namur NE43, the linear range is from 3.8 to 20.5 mA (Current output range="4 to 20 mA") or from 0 to 20.5 mA (Current output range="0 to 20 mA"). If the range is exceeded or undershot, the current value stops at the range limit and a diagnostics message (460 or 461) is output.
Error current	0.0 to 23.0 mA Factory setting 21.5 mA	The function meets NAMUR NE43. Set the current value that should be output at the current outputs in the event of an error.
 The value for "Error current" should be outside the measuring range. If you decided that your Current output range = "0 to 20 mA", you should set an error current between 20.1 and 23 mA. If the Current output range = "4 to 20 mA" you could also define a value < 4 mA as the error current. The device allows an error current within the measuring range. In such instances pay attention to possible affects this may have on your process.		
Alarm delay	0 to 9999 s Factory setting 0 s	The system only displays the errors that are present longer than the set delay time. This makes it possible to suppress messages that only occur briefly and are caused by normal process-specific fluctuations.
Device Hold	Options <ul style="list-style-type: none"> ■ Disabled ■ Enabled Factory setting Disabled	You can enable an immediate, general hold here. The function acts in the same way as the "HOLD" soft key in the measuring menus.

10.2.2 Date and time

Path: Menu/Setup/General settings/Date/Time

Function	Options	Info
Set date	Depends on the format	Editing mode: Day (two-digit): 01 to 31 Month (two-digit): 01 to 12 Year (four-digit): 1970 to 2106

Path: Menu/Setup/General settings/Date/Time

Function	Options	Info
Set time	Depends on the format	Editing mode: hh (hour): 00 to 23 / 0 am to 12 pm mm (minutes): 00 to 59 ss (seconds): 00 to 59
▶ Extended setup		
Date format	Options <ul style="list-style-type: none"> ▪ DD.MM.YYYY ▪ YYYY-MM-DD ▪ MM-DD-YYYY Factory setting DD.MM.YYYY	Decide which date format you want to use.
Time format	Options <ul style="list-style-type: none"> ▪ HH:MM am (12h) ▪ HH:MM (24h) ▪ HH:MM:SS (24h) Factory setting HH:MM:SS (24h)	Decide whether you want to use the 12-hour or 24-hour clock. Seconds can also be displayed with the latter version.
Time zone	Options <ul style="list-style-type: none"> ▪ None ▪ Choice of 35 time zones Factory setting None	If no time zone is selected, then Greenwich Mean Time is used (London).
DST	Options <ul style="list-style-type: none"> ▪ Off ▪ Europe ▪ USA ▪ Manual Factory setting Off	The controller adapts the summertime/normal time changeover automatically if you choose European or American daylight saving time. Manual means that you can specify the start and end of daylight saving time yourself. Here, two additional submenus are displayed in which you specify the changeover date and time.

10.2.3 Automatic hold**Path: Menu/Setup/General settings/Automatic hold**

Function	Options	Info
▶ Device specific hold		
Setup menu	Options <ul style="list-style-type: none"> ▪ Disabled ▪ Enabled Factory setting Disabled	Decide whether a hold should be output at the current output when the particular menu is opened.
Diagnostics menu		
Calibration active		

Path: Menu/Setup/General settings/Automatic hold

Function	Options	Info
Hold release time	0 to 600 s Factory setting 0 s	The hold is maintained for the duration of the delay time when you switch to the measuring mode.

 If a device-specific hold is activated, any cleaning previously started is interrupted. When a hold is active you can only start manual cleaning.

10.2.4 Logbooks

Logbooks record the following events:

- Calibration/adjustment events
- Operator events
- Diagnostic events

Here you define how the logbooks should store the data.

In addition, you can also define individual data logbooks . Assign the logbook name and select the measured value to be recorded. You can set the scan time (Scan time) individually for every data logbook.

Further information on the logbooks →  12.1.

Path: Menu/Setup/General settings/Logbooks

Function	Options	Info
Logbook ident	Free text	Part of the file name when exporting a logbook.
Event logbook	Options <ul style="list-style-type: none"> ■ Off ■ Ring buffer ■ Fill up buffer Factory setting Ring buffer	All diagnostic messages are recorded Ring buffer If the memory is full, the most recent entry automatically overwrites the oldest entry. Fill up buffer If the memory is full, there is an overflow, i.e. no new values can be saved. The controller displays a corresponding diagnostic message. The memory then has to be cleared manually.
► Overflow warnings <i>Event logbook="Fill up buffer"</i>		
Calibration logbook	Options <ul style="list-style-type: none"> ■ Off ■ On Factory setting Off	Decide whether you want to receive a diagnostic message from the controller in the event of fill-up buffer overrun of the logbook in question.
Diagnostic logbook		
Configuration logbook		
Source of data	Read only	The assigned measuring channel is displayed
Measuring parameter	Read only	Plain-text information on the parameter that is being recorded

Path: Menu/Setup/General settings/Logbooks

Function	Options	Info
Main value	Read only	Information on the main value and the unit.
Unit	Read only	
▶ Data logbooks		
▶ New		You can create a maximum of 8 data logbooks.
Logbook name	Customized text, 20 characters	
Source of data	Options <ul style="list-style-type: none"> ▪ Sensor inputs ▪ Controller ▪ Current inputs ▪ Fieldbus signals ▪ Mathematical functions Factory setting None	Select a data source for the logbook entries. You can choose from connected sensors, available controllers, current inputs, fieldbus signals and mathematical functions.
Measured value	Options <ul style="list-style-type: none"> ▪ depend onSource of data Factory setting None	You can record different measured values depending on the data source.
Scan time	00:00:01 to 01:00:00 Factory setting 00:01:00	Minimum interval between two entries Format: HH:MM:SS
Data logbook	Options <ul style="list-style-type: none"> ▪ Off ▪ Ring buffer ▪ Fill up buffer Factory setting Off	Ring buffer If the memory is full, the most recent entry automatically overwrites the oldest entry. Fill up buffer If the memory is full, there is an overflow, i.e. no new values can be saved. The controller displays a corresponding diagnostic message. The memory then has to be cleared manually.
▷ Add another logbook	Action	<i>Only if you want to create another data logbook immediately.</i> You add a new data logbook at a later date using ▶ New.
▷ Finished	Action	This allows you to exit the menu ▶ New.
▷ Start/stop simultaneously	Action	Appears if you have created more than one data logbook. With one mouse click, you can start or stop recording all the data logbooks.
▶ "Logbook name"		The name of this submenu is based on the name of the logbook and only appears once you have created a logbook.
 This menu appears several times if you have several data logbooks.		
Source of data	Read only	This is for information purposes only. If you want to record another value, delete this logbook and create a new data logbook.
Measured value		

Path: Menu/Setup/General settings/Logbooks

Function	Options	Info
Log time left <i>Data logbook="Fill up buffer"</i>	Read only	Displays the days, hours and minutes remaining until the logbook is full.
Log size <i>Data logbook="Ring buffer"</i>	Read only	Displays the number of entries remaining until the logbook is full.
Logbook name	Customized text, 20 characters	You can change the name here again.
Scan time	00:00:01 to 01:00:00 Factory setting 00:01:00	As above Minimum interval between two entries Format: HH:MM:SS
Data logbook	Options <ul style="list-style-type: none"> ▪ Off ▪ Ring buffer ▪ Fill up buffer Factory setting Off	Ring buffer If the memory is full, the most recent entry automatically overwrites the oldest entry. Fill up buffer If the memory is full, there is an overflow, i.e. no new values can be saved. The controller displays a corresponding diagnostic message. The memory then has to be cleared manually.
▶ Line plotter		Menu to define the graphic display
Axes	Options <ul style="list-style-type: none"> ▪ Off ▪ On Factory setting On	Should the axes (x, y) be displayed (On) or not (Off)?
Orientation	Options <ul style="list-style-type: none"> ▪ Horizontal ▪ Vertical Factory setting Horizontal	You can choose whether the value curves should be displayed from left to right ("Horizontal") or from top to bottom ("Vertical"). If you want to display two data logbooks simultaneously, make sure that both logbooks have the same settings here.
X-Description	Options <ul style="list-style-type: none"> ▪ Off ▪ On Factory setting On	Decide whether a description should be displayed for the axes and whether gridlines should be shown. In addition, you can also decide whether pitches should be displayed.
Y-Description		
Grids		
Pitches		
X Pitch/Grid distance	10 to 50%	Specify the pitches.
Y Pitch/Grid distance	Factory setting 10 %	
▷ Remove	Action	This action removes the data logbook. Any data that have not been saved are lost.

Example for setting up a new data logbook (for sensors)

1. Menu/Setup/General settings/Logbooks/Data logbooks/New:
 - a. Logbook name: Assign a name, e.g. "01".
 - b. Source of data: Select a data source, e.g. the sensor connected to channel 1 (CH1).
 - c. Measured value: Select the measured value that you want to record.
 - d. Scan time: Specify the interval between two logbook entries.
 - e. Data logbook: Activate the logbook. Specify the type of memory, "Ring buffer" or "Fill up buffer".
2. ../Finished: Execute this action.
--> Your new logbook now appears in the list of data logbooks.
3. Select the data logbook with the name "01".
4. If you selected "Fill up buffer" you can also decide whether you want to receive a diagnostic message in the event of memory overrun.
5. Depending on the type of memory selected, you receive information about the memory space (for "Ring buffer") or the time remaining until memory overrun "Fill up buffer").
6. Define the graphic display mode in the "Line plotter" submenu.

10.2.5 Extended setup

Diagnostics settings

The list of diagnostic messages displayed depends on the path selected. There are device-specific messages, and messages that depend on what sensor is connected.

Path: ... /Extended setup/Diagnostics settings/Diag. behavior

Function	Options	Info
List of diagnostic messages		Select the message to be changed. Only then can you make the settings for this message.
Diag. code	Read only	
Diagnostic message	Options <ul style="list-style-type: none"> ▪ On ▪ Off Factory setting Depends on the message	You can deactivate or reactivate a diagnostics message here. Deactivating means: <ul style="list-style-type: none"> ▪ No error message in the measuring mode ▪ No error current at the current output
Error current	Options <ul style="list-style-type: none"> ▪ On ▪ Off Factory setting Depends on the message	Decide whether an error current should be output at the current output if the diagnostic message display is activated.
Status signal	Options <ul style="list-style-type: none"> ▪ Maintenance (M) ▪ Out of specification (S) ▪ Function check (C) ▪ Failure (F) Factory setting Depends on the message	The messages are divided into different error categories in accordance with NAMUR NE 107. Decide whether you want to change a status signal assignment for your application.

Path: ... /Extended setup/Diagnostics settings/Diag. behavior

Function	Options	Info
Diag. output	Options <ul style="list-style-type: none"> ■ None Factory setting None	Before you can assign the message to an output, you must first configure a relay output to "Diagnostics" (Menu/Setup/Outputs, assign the "Diagnostics" function and set the Operating mode to "as assigned").
Cleaning program (for sensors)	Options <ul style="list-style-type: none"> ■ None ■ Cleaning 1 ■ Cleaning 2 ■ Cleaning 3 ■ Cleaning 4 Factory setting None	Decide whether the diagnostic message should trigger a cleaning program. You can define the cleaning programs under: Menu/Setup/Additional functions/Cleaning.
Detail information	Read only	Here you can find more information on the diagnostic message and instructions on how to resolve the problem.

HART bus address

If Multidrop is active (Bus address > 0), the current at current output 1 is fixed at 4 mA. Here, it does not matter what function has been assigned to the output (measured value/controller etc.). Current simulation is no longer possible.

Path: Menu/Setup/General settings/Extended setup/HART

Function	Options	Info
Bus address	0 to 63 Factory setting 0	You can change the device address to integrate several HART devices in a single network (Multidrop mode).

 If you reset the device to the factory settings (Diagnostics/Systemtest/Reset/Factory default), the bus address is not reset. Your setting is retained.

PROFIBUS DP

Path: Menu/Setup/General settings/Extended setup/PROFIBUS

Function	Options	Info
Enable	Options <ul style="list-style-type: none"> ■ Off ■ On Factory setting Off	You can switch off PROFIBUS communication at this point. The software can then only be accessed via local operation.

Path: Menu/Setup/General settings/Extended setup/PROFIBUS

Function	Options	Info
Termination	Read only	If the device is the last in the bus, you can terminate via the hardware. --> BA01225C, "Electrical connection" section
Bus address	1 to 125	If you have addressed the bus via hardware (DIP switches on the module, --> BA01225C), you can only read the address here. If an invalid address is set via the hardware, you have to assign a valid address for your device either here or via the bus.
Ident number	Options <ul style="list-style-type: none"> ▪ Automatic ▪ PA-Profile 3.02 (9760) ▪ Liquiline CM44x (155D) ▪ Liquiline CM44xR (155D) ▪ Liguistation CSFxx (155C) Factory setting Automatic	

Modbus**Path: Menu/Setup/General settings/Extended setup/Modbus**

Function	Options	Info
Enable	Options <ul style="list-style-type: none"> ▪ Off ▪ On Factory setting Off	You can switch off Modbus communication at this point. The software can then only be accessed via local operation.
Termination	Read only	If the device is the last in the bus, you can terminate via the hardware. --> BA00444C(CM44x) or BA01225C (CM44xR), "Electrical connection" section
Settings		
Transmission Mode	Options <ul style="list-style-type: none"> ▪ TCP ▪ RTU ▪ ASCII 	The transmission mode is displayed depending on the version ordered. In the case of RS485 transmission, you can choose between "RTU" and "ASCII".
Watchdog	0 to 999 s Factory setting 5 s	If no data transmission takes place for longer than the time set, this is an indicator that communication has been interrupted. After this time, input values received via the Modbus are considered to be invalid.

EtherNet/IP

 EtherNet Industrial Protocol is an open fieldbus standard of the Open DeviceNet Vendor Association (ODVA). --> www.odva.org

Path: Menu/Setup/General settings/Extended setup/Ethernet

Function	Options	Info
Enable	Options <ul style="list-style-type: none"> ■ Off ■ On Factory setting On	You can switch ethernet communication on and off at this point.
Settings		
Link settings	Options <ul style="list-style-type: none"> ■ Auto negotiation ■ 10MBps Half duplex ■ 10MBps Full duplex ■ 100MBps Half duplex ■ 100MBps Full duplex Factory setting Auto negotiation	Transmission methods of the communication channels <ul style="list-style-type: none"> ■ Full duplex: Data can be transmitted simultaneously in both directions. ■ Half-duplex: Data can only be transmitted alternately in both directions, i.e. not at the same time. Source: Wikipedia
DHCP	Options <ul style="list-style-type: none"> ■ Off ■ On Factory setting Off	The Dynamic Host Configuration Protocol (DHCP) makes it possible to assign the network configuration to clients via a server. With DHCP, it is possible to automatically integrate the device into an existing network without the need for manual configuration. Normally, the client need only be configured for automatic retrieval of the IP addresses. During startup, the IP address, the netmask and the gateway are retrieved from a DHCP server.
IP-Address	xxx.xxx.xxx.xxx Factory setting 192.168.1.212	An IP address is an address in computer networks which are based on the Internet protocol (IP).
Netmask	xxx.xxx.xxx.xxx Factory setting 255.255.255.0	On the basis of the IP address of a device, the netmask specifies which IP addresses this device searches for in its own network and which addresses it could access in other networks via a router. It therefore divides the IP address into a network part (network prefix) and a device part. The network part must be identical for all devices in the individual network, and the device part must be different for every device within the network.
Gateway	x.x.x.x Factory setting 0.0.0.0	A gateway (protocol converter) enables communication between networks that are based on completely different protocols.
MAC-Address	Read only	The MAC address (Media Access Control address) is the hardware address of every individual network adapter which is used to uniquely identify the device in a computer network.
EtherNetIP Port 44818	Read only	A port is a part of an address which assigns data segments to a network protocol.

Web server

Path: Menu/Setup/General settings/Extended setup/Webserver

Function	Options	Info
Webserver	Options <ul style="list-style-type: none"> ■ Off ■ On Factory setting On	You can switch web server communication on and off at this point.
Webserver TCP Port 80	Read only	The Transmission Control Protocol (TCP) is an arrangement (protocol) as to how data should be exchanged between computers. A port is a part of an address which assigns data segments to a network protocol.
Webserver login	Options <ul style="list-style-type: none"> ■ Off ■ On Factory setting On	You can switch user administration on and off at this point. This makes it possible to create multiple users with password access.
User administration		
List of users already created	View/edit	You can change user names or passwords or delete users. A user is already created at the factory: "admin" with password "admin".
New user:		
Name	Free text	Create new user 1. Press "INSERT" 2. Assign any name to the new user. 3. Select a password for the user. 4. Confirm the password. ↵ You can now change the password at any time.
Enter new user password	Free text	
Confirm new user password	Free text	
Change user password	Free text	

Data management

Firmware update

Please contact your local sales office for information on firmware updates available for your controller and its compatibility with earlier versions.

Your **current firmware version** can be found at: Menu/Diagnostics/System information/Software version.

To install a firmware update, you must have the update available on an SD card.

1. Insert the SD card into the controller card reader.
2. Go to: Menu/Setup/General settings/Extended setup/Data management/Firmware update.
 - ↳ The update files on the SD card are displayed.
3. Select the desired update and select yes when the following question is displayed: The current firmware will be overwritten. After this the device will reboot. Do you want to proceed?
 - ↳ The firmware is loaded and the device is then started with the new firmware.

Saving the setup

Saving the setup gives you the following advantages:

- Quick and easy to restore a setup following a firmware update
- Copying settings for other devices
- Quick and easy switching between various setups, e.g. for different user groups or for recurring sensor type change
- Restoring a tried-and-tested setup, e.g. if you have changed a lot of settings and no longer know what the original settings were

1. Insert the SD card into the controller card reader.
2. Go to: Menu/Setup/General settings/Extended setup/Data management/canada.
3. Assign a file name (Name).
4. Then select "Save".
5. If you have already assigned the file name, you will be asked whether you want to overwrite the existing setup.
6. Select "OK" to confirm, or cancel the action and give the file a new name.
 - ↳ Your setup is stored on the SD card and you can upload it quickly to the device at a later date.

Loading the setup

You can load a setup you have saved quickly and easily

 When you load a setup, the current configuration is overwritten. Note that cleaning and controller programs could be active. Do you want to continue anyway?

1. Insert the SD card into the controller card reader.
2. Go to: Menu/Setup/General settings/Extended setup/Data management/Load setup.
 - ↳ A list of all the setups on the SD card is displayed.
3. Select the desired setup.
 - ↳ The device then displays the following message: The current parameters will be overwritten and the device will reboot. Warning: Please note that cleaning and controller programs can be active. Do you want to proceed?
4. Select "OK" to confirm or cancel the action.
 - ↳ The desired setup is restored after restarting the device.

Exporting the setup

Exporting the setup gives you the following advantages:

- Export in XML format with a stylesheet for formatted display in an XML-compatible application such as Microsoft Internet Explorer
 - Importing the data (drag and drop the XML file into a browser window)
1. Insert the SD card into the controller card reader.
 2. Go to: Menu/Setup/General settings/Extended setup/Data management/Export setup.
 3. Assign a file name (Name).
 4. Then select "Export".
 5. If you have already assigned the file name, you will be asked whether you want to overwrite the existing setup.
 6. Select "OK" to confirm, or cancel the action and give the file a new name.
 - ↳ Your setup is saved on the SD card in a folder named "Device".
-  You cannot upload the exported setup to the device again. You must use the "Save setup" function for this purpose. This is the only way you can save a setup to an SD card and reload it later on or upload it to other devices.

Activation code

You require activation codes for:

- Additional functions
- Software upgrades

 If activation codes are available for your device, these codes are provided on the inner nameplate. The corresponding device functions are activated at the factory. You only require the codes if servicing the device.

1. Enter the activation code: Menu/Setup/General settings/Extended setup/Data management/Activation code.
2. Confirm your entry.
 - ↳ Your new hardware or software function is activated and can be configured.

The table below tells you what functions an activation code enables:

Function	Activation code beginning with:
Second Memosens input (CM442R only)	062...
Two current outputs (BASE-E module only)	081...
HART	0B1...
PROFIBUS DP	0B3...
Modbus TCP	0B4...
Modbus RS485	0B5...
EtherNet/IP	0B6...
Measuring range switching, set 1	211...
Measuring range switching, set 2 ¹⁾	212...
Feedforward control	220...
Chemoclean Plus	25...

- 1) When you order the "Measuring range switching" option, you receive two activation codes. Enter both codes to have two sets for measuring range switching.

10.3 Current inputs

The input can be used as the data source for limit switches and logbooks, for example. Furthermore, external values can be made available as set points for controllers.

Path: Menu/Setup/Inputs/Current input %0V xy¹⁾

Function	Options	Info
Mode	Options <ul style="list-style-type: none"> ■ Off ■ 0 to 20 mA ■ 4 to 20 mA Factory setting 4 to 20 mA	Select the same current range as in the data source (connected device).
Input mode	Options <ul style="list-style-type: none"> ■ Parameter ■ Current Factory setting Current	Select the input variable.
Meas. value format	Options <ul style="list-style-type: none"> ■ # ■ #.# ■ #.## ■ #.### Factory setting #.#	Specify the number of decimal places.
Parameter name <i>Input mode "Parameter"</i>	Free text	Assign a useful name, such as the parameter name, which the data source uses.
Unit of measure <i>Input mode "Parameter"</i>	Free text	You cannot choose the unit from a list. If you want to use a unit, you must enter it manually here.
Lower range value <i>Input mode "Parameter"</i>	-20.0 to Upper range value <engineering unit> Factory setting 0.0 <engineering unit>	Enter the measuring range. The lower and upper range values are assigned to the 0 or 4 mA value and the 20 mA value respectively. The system uses the engineering unit which you entered beforehand.
Upper range value <i>Input mode "Parameter"</i>	Upper range value to 10000.0 <engineering unit> Factory setting 10.0 <engineering unit>	
Damping	0 to 60 s Factory setting 0 s	The damping causes a floating average curve of the measured values over the time specified.

1) x;y = slot no. : input number

10.4 Outputs

10.4.1 Current outputs

Under Menu/Setup/General settings set the current range of 0 to 20 mA or 4 to 20 mA.

Possible applications

- For outputting a measured value to a process control system or an external recorder
- For outputting a manipulated variable to connected actuators

 The current output curve is always linear.

Path: Menu/Setup/Outputs/Current output

Function	Options	Info
Current output	Options <ul style="list-style-type: none"> ■ On ■ Off Factory setting Off	Use this function to activate or deactivate a variable being output at the current output
Source of data	Options <ul style="list-style-type: none"> ■ None ■ Connected inputs Factory setting None	The sources of data on offer depend on your device version. all the sensors and controllers connected to inputs are available for selection.
Measured value	Options <ul style="list-style-type: none"> ■ None ■ Depends on theSource of data Factory setting None	The measured value you can select depends on the option selected under "Source of data".
<p> The next table lists the measured values available depending on the data source.</p>		
Range lower value	Selection range and factory settings depend on: "Measured value"	You can output the entire measuring range of the "Measured value" or just some of it at the current output. For this purpose, specify the upper and lower range values in accordance with your requirements.
Range upper value		
Hold behavior	Options <ul style="list-style-type: none"> ■ Freeze ■ Fixed value ■ None Factory setting Depends on the channel:output	Freeze The device freezes the last current value. Fixed value You define a fixed current value that is output at the output. None A hold does not affect this current output.
Hold current <i>Hold behavior="Fixed value"</i>	0.0 to 23.0 mA Factory setting 22.0 mA	Specify which current should be output at this current output in the event of a hold.

Measured value depending on the Source of data

Source of data	Measured value
pH Glass	Options
pH ISFET	<ul style="list-style-type: none"> ▪ Raw value mV ▪ pH ▪ Temperature
ORP	Options <ul style="list-style-type: none"> ▪ Temperature ▪ ORP mV ▪ ORP %
Oxygen (amp.)	Options
Oxygen (opt. WW)	<ul style="list-style-type: none"> ▪ Temperature ▪ Partial pressure ▪ Concentration liquid ▪ Saturation ▪ Raw value nA (only Oxygen (amp.)) ▪ Raw value µs (only Oxygen (opt. WW))
Cond i	Options
Cond c	<ul style="list-style-type: none"> ▪ Temperature ▪ Conductivity ▪ Resistance (only Cond c) ▪ Concentration (only Cond i)
Chlorine	Options <ul style="list-style-type: none"> ▪ Temperature ▪ Current ▪ Concentration
ISE	Options <ul style="list-style-type: none"> ▪ Temperature ▪ pH ▪ Ammonium ▪ Nitrate ▪ Potassium ▪ Chloride
TU/TS	Options <ul style="list-style-type: none"> ▪ Temperature ▪ Turbidity g/l ▪ Turbidity FNU
Nitrate	Options <ul style="list-style-type: none"> ▪ Temperature ▪ NO3 ▪ NO3-N
SAC	Options <ul style="list-style-type: none"> ▪ Temperature ▪ SAC ▪ Transm. ▪ Absorption ▪ COD ▪ BOD

Measured value depending on the Source of data

Source of data	Measured value
Controller 1	Options <ul style="list-style-type: none"> ■ Bipolar (only current outputs) ■ Unipolar+ ■ Unipolar-
Controller 2	
Mathematical functions	All the mathematical functions can also be used as a data source and the calculated value can be used as the measured value.

Outputting the controller manipulated variable via the current output

Assign "Unipolar+" to the output to which an actuator that can increase the measured value is connected. Assign "Unipolar-" to the output to which an actuator that can decrease the measured value is connected.

To output the manipulated variable of a two-sided controller, positive manipulated variables and negative manipulated variables generally have to be output to different actuators, as most actuators are able to influence the process in one direction only (not in both). For this purpose, the instrument splits the bipolar manipulated variable y into two unipolar manipulated variables, $y+$ and $y-$.

Only the two unipolar manipulated variable parts are available for selection for outputting to modulated relays. If outputting the values via a current output, you also have the possibility of outputting the bipolar manipulated variable y to one current output only (split range).

10.4.2 Alarm relay and optional relays

Outputting the status of a limit switch

Function="LimitSwitch"

Function	Options	Info
Source of data	Options <ul style="list-style-type: none"> ■ None ■ Limit switch 1 ■ Limit switch 2 ■ Limit switch 3 ■ Limit switch 4 ■ Limit switch 5 ■ Limit switch 6 ■ Limit switch 7 ■ Limit switch 8 Factory setting None	Select the limit switch via which the status of the relay is to be output. The limit switches are configured in the "Setup/Additional functions/Limit switches" menu.

Outputting the manipulated variable of a controller

To output a controller manipulated variable via a relay, the relay is modulated. The relay is energized (pulse, t_1) and is then de-energized (interval, t_0).

Function="Controller"

Function	Options	Info
Source of data	Options <ul style="list-style-type: none"> ▪ None ▪ Controller 1 ▪ Controller 2 Factory setting None	Select the controller that should act as the data source.
Operating mode	Options <ul style="list-style-type: none"> ▪ PWM ▪ PFM Factory setting PWM	PWM=pulse width modulation PFM=pulse frequency modulation

Types of modulation:

1. PWM (pulse width modulation):

The duty cycle is varied within a period T ($T=t_1+t_0$). The cycle duration remains constant.

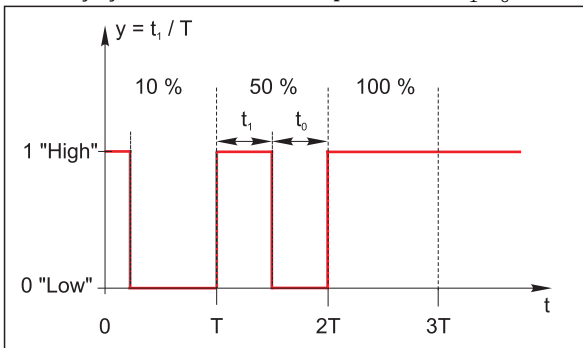

Typical application: solenoid valve

2. **PFM** (pulse frequency modulation):

Here, pulses of a constant length (t_1) are output and the interval between the pulses varies (t_0). At a maximum frequency, $t_1 = t_0$.

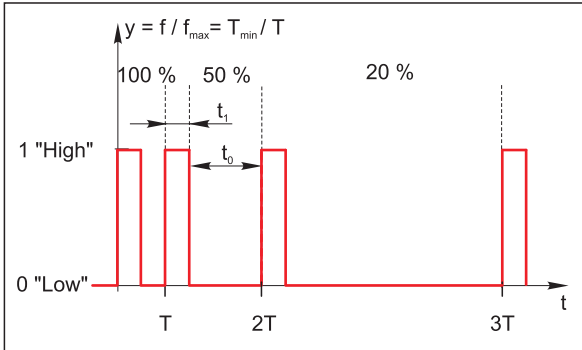

Typical application: dosing pump

Function="Controller"

Function	Options	Info
Actuator type	Options <ul style="list-style-type: none"> ■ None ■ Unipolar- ■ Unipolar+ Factory setting None	Here you specify what part of the controller should power the relay. "Unipolar+" is the part of the manipulated variable which the controller uses to increase the process value (e.g. for heating purposes). On the other hand, select "Unipolar-" if you want to connect an actuator to the relay that causes the controlled variable to drop (e.g. for cooling purposes).
Cycle duration <i>Operating mode="PWM"</i>	(Shortest turn-on time) to 999.0 s Factory setting 10.0 s	Specify the cycle duration within which the duty cycle should be varied (only PWM).
The settings for Cycle duration and Shortest turn-on time mutually affect one another. The following applies: Cycle duration ≥ Shortest turn-on time.		
Shortest turn-on time <i>Operating mode="PWM"</i>	0.3 s to (Cycle duration) Factory setting 0.3 s	Pulses that are shorter than this limit value are not output in order to conserve the actuator.
Maximum frequency <i>Operating mode="PFM"</i>	1 to 180 min ⁻¹ Factory setting 60 min ⁻¹	Maximum number of pulses per minute The controller calculates the pulse duration based on this setting.

Outputting diagnostics messages via the relay

You can output two categories of diagnostics messages via the relay:

1. Diagnostic messages from one of the 4 Namur classes
(--> see the "Adjusting diagnostics information" section for more information on the Namur classes)
2. Diagnostics messages which you have individually assigned to the relay output

A message is individually assigned to the relay output at 2 specific points in the menu:

- Menu/Setup/General settings/Diagnostics/Device behavior
(device-specific messages)
- Menu/Setup/Inputs/ ../Diagnostics settings/Diag. behavior
(sensor-specific messages)

 Before being able to assign the relay output to a special message in "Device behavior", you must first configure Outputs/relay x:y or /Alarm relay/Function="Diagnostics".

Function="Diagnostics"

Function	Options	Info
Operating mode	Options <ul style="list-style-type: none"> ■ as assigned ■ Namur M ■ Namur S ■ Namur C ■ Namur F Factory setting as assigned	as assigned If this option is selected, the diagnostics messages which you have individually assigned to the relay are output via the relay. Namur M ... F If you decided to use one of the Namur classes, all the messages that are assigned to the individual class are output via the relay. You can also change the Namur class assignment for every diagnostics message. (Menu/Setup/General settings/Diagnostics/Device behavior or Menu/Setup/Inputs/ ../Diagnostics settings/Diag. behavior)
Attributed diagnostic messages <i>Operating mode="as assigned"</i>	Read only List of diagnostic messages	All the messages assigned to the relay output appear on the display. You do not have the option of editing the information here.

Outputting the status of a cleaning function

Function="Cleaning"

Function	Options	Info
Assignment	Options <ul style="list-style-type: none"> ■ None ■ Cleaning 1 - Water ■ Cleaning 1 - Cleaner ■ Cleaning 2 - Water ■ Cleaning 2 - Cleaner ■ Cleaning 3 - Water ■ Cleaning 3 - Cleaner ■ Cleaning 4 - Water ■ Cleaning 4 - Cleaner Factory setting None	Here you can specify how a cleaning function should be displayed for the alarm relay. You can define the cleaning programs under: Menu/Setup/Additional functions/Cleaning.

10.4.3 HART

Specify which device variables should be output via HART communication.

You can define a maximum of 16 device variables:

- ▶ Define the data source. You can choose from the sensor inputs and the controllers.
- ▶ From the source, select the measured value that should be output.
- ▶ Define how the device should behave in the event of a "Hold".
- ▶ The configuration options for "Source of data", "Measured value" and "Hold behavior" are identical to those described in the "Outputs/Current outputs" section. Please refer to this section for more information.
- ▶ Please note that if you select Hold behavior="Freeze", the system not only flags the status but also actually "freezes" the measured value.

 More information is provided in BA00486C "HART communication".

10.4.4 PROFIBUS DP

Device variables (device --> PROFIBUS)

Specify which process values should be mapped to the PROFIBUS function blocks and are thereby available for transmission via PROFIBUS communication.

You can define a maximum of 16 device variables (AI Blocks):

- ▶ Define the data source.
Choose between sensor inputs, current inputs or mathematical functions whose measured values should be transmitted.
- ▶ From the data source, select the measured value to be transmitted.

In addition, you can define 8 binary variables (DI Blocks):

- ▶ Define the data source.
Select the limit switch or relay whose status should be transmitted.

PROFIBUS variables (PROFIBUS --> device)

Not in the "Menu/Setup/Outputs" menu

- ▶ A maximum of 4 analog (AO) and 8 digital (DO) PROFIBUS variables are available as measured values in the controller, limit switch or current output menus.
- ▶ Example: Using an AO or DO value as the set point for the controller
 - "Menu/Setup/Additional functions/Controller 1" menu
 - In the menu mentioned, define PROFIBUS as the data source.
 - Select the desired analog output (AO) or digital output (DO) as the measured value.

 Additional information is provided in the SD01188C document on the CD.

10.4.5 Modbus RS485 and Modbus TCP

Specify which process values should be output via Modbus RS485 communication or via Modbus TCP.

In the case of Modbus RS485, you can switch between the RTU and the ASCII protocol.

You can define a maximum of 16 device variables:

- ▶ Define the data source. You can choose from sensor inputs and controllers.
- ▶ From the source, select the measured value that should be output.
- ▶ Define how the device should behave in the event of a "Hold".
- ▶ The configuration options for "Source of data", "Measured value" and "Hold behavior" are identical to those described in the "Outputs/Current outputs" section. Please refer to this section for more information.
- ▶ Please note that if you select Hold behavior="Freeze", the system not only flags the status but also actually "freezes" the measured value.

 Additional information is provided in the SD01189C document.

10.4.6 EtherNet/IP

Specify which process values should be output via EtherNet/IP communication.

You can define a maximum of 16 analog device variables (AI):

- ▶ Define the data source. You can choose from sensor inputs, binary inputs and controllers.
- ▶ From the source, select the measured value that should be output.
- ▶ Define how the device should behave in the event of a "Hold".
- ▶ In the case of controllers, also specify the type of actuating variable.
- ▶ Please note that if you select Hold behavior="Freeze", the system not only flags the status but also actually "freezes" the measured value.

Furthermore you can define 8 digital device variables (DI):

- ▶ You only define the data source here. You can choose from relays, binary inputs and limit contactors.

 Additional information is provided in the SD01293C document.

10.5 Binary inputs and outputs

The optional "DIO" hardware module with 2 digital inputs and 2 digital outputs enables the following:

- via a digital input signal
 - measuring range switching for conductivity (upgrade code required, see accessories)
 - an external hold
 - a cleaning interval to be triggered
 - a PID controller to be switched on and off, e.g. via the proximity switch of CCA250
 - the use of the input as an "analog input" for pulse-frequency modulation (PFM)
- via a digital output signal
 - the static transmission (similar to a relay) of diagnostic states, point level switch states etc.
 - the dynamic transmission (comparable to a non-wearing "analog output") of PFM signals, e.g. to control dosing pumps.

10.5.1 Application examples

Chlorine control with feedforward control

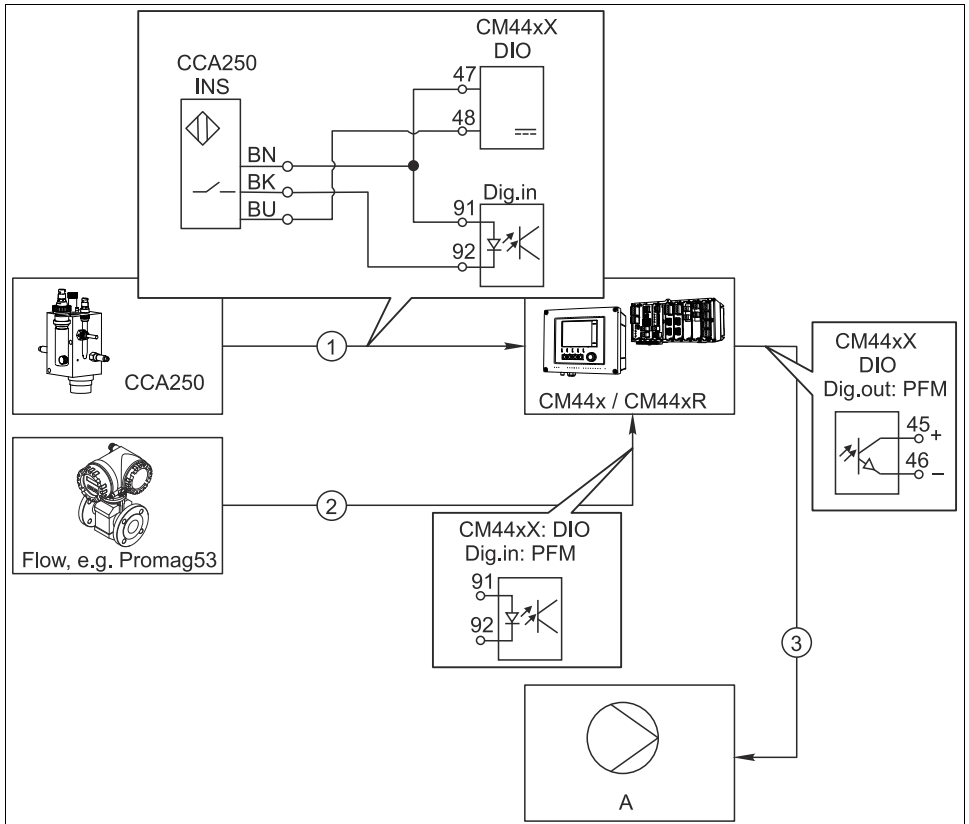



Fig. 59: Example of chlorine control with feedforward control

- 1 Connection of the inductive proximity switch INS of the CCA250 assembly at the digital input of the DIO module for enabling the controller
 - 2 Connection of the signal from a flowmeter to the digital input of the DIO module using the pulse-frequency modulation (=PFM, setting in the Liquiline firmware) for feedforward control
 - 3 Activation of a (pulse) dosing pump via a digital output of the DIO module using the PFM
- A Dosing pump

Chlorine control with feedforward control

Utilize the advantage of the effectively wear-free control with binary outputs versus a control system with relay. It is possible to achieve virtually continuous dosing using a dosing pump with higher input frequency through pulse frequency modulation (PFM).

1. Connect the proximity switch INS from assembly CCA250 to a digital input of the DIO module. Configure a controller in the software, selecting the binary input for the function "Controller Enable" which the proximity switch is connected to. Leave the "Signal type" in the inputs menu at the factory setting "Static signal" as the selected input.
 2. Connect the flowmeter value to the second input of the DIO module. Set the "Signal type" for this input to "PFM" in the inputs menu and select the corresponding measured value.
 - ↳ You can now use this input in the controller menu as the disturbance variable for your controller ¹⁾. To do so, in the submenu "Disturbance variable" select the binary input to which you connected the flow measured value as the "Source of data."
 3. You can activate a dosing pump through PFM via a digital output of the DIO module. In the outputs menu, set the "Signal type" of the corresponding binary output to "PFM" and use the previously configured controller as the "Source of data." Observe your dosing's direction of action, so that you correctly install the "Actuator type."
-  You must make additional settings in the controller menu to fully customize the control to your process conditions.

1) An activation code, Order No. 71211288, is necessary for the "feedforward control" function.

CM44xR as cleaning master

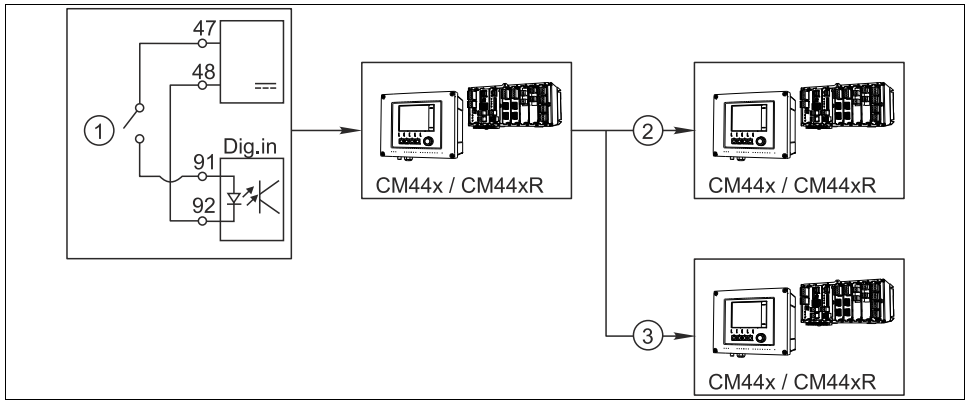

Fig. 60: Example of a central cleaning control

a0020124

- 1 External cleaning trigger at the binary input
- 2 Transferring the external hold over binary output to other measuring devices without connected cleaning functions
- 3 Transferring the cleaning trigger over a binary output to other self-cleaning measuring points

CM44xR as "cleaning master"

1. An external trigger actuates a cleaning at the master. A cleaning unit is connected over a relay or a binary output, for example.
2. The cleaning trigger is transferred to another device via a binary output. This does not have its own connected cleaning unit, but its sensors are installed in the medium affected by cleaning the master and are set to hold by the trigger.
3. The trigger is transferred via an additional binary output to another device, whose connected sensors have their own cleaning units. The signal can be used to simultaneously activate a self-cleaning with the master.

10.5.2 Binary input configuration

Path: Menu/Setup/Inputs/Binary input x:y¹⁾

Function	Options	Info
Binary input	Options <ul style="list-style-type: none"> ■ Off ■ On Factory setting On	Switching the input on/off
Signal type	Options <ul style="list-style-type: none"> ■ Static signal ■ PFM Factory setting Static signal	Select the signal type. Static signal Use this setting to read out the position of, for example, an on/off switch, an inductive proximity switch or a PLC binary output. Signal application: for measuring range switching, acceptance of an external hold, as a cleaning trigger or for controller activation PFM The PFM setting produces a pulse-frequency-modulated signal that is subsequently available on the device as a quasi-continuous process value. Example: Measuring signal of a flowmeter
<i>Signal type= "Static signal"</i>		
Signal level	Options <ul style="list-style-type: none"> ■ High ■ Low Factory setting High	Determine which input signal levels should activate, for example, measuring range switching or a cleaning. High Input signals between 11 and 30 V DC Low Input signals between 0 and 5 V DC
<i>Signal type= "PFM"</i>		
Max. frequency	100.00 to 1000.00 Hz Factory setting 1000.00 Hz	Maximum frequency of the PFM input signal Is to equal the maximum possible upper limit of the measuring range. If the value selected is too small, higher frequencies will not be detected. If the value is too large, on the other hand, the resolution for small frequencies will be relatively inexact.
Meas. value format	Options <ul style="list-style-type: none"> ■ # ■ #.# ■ #.## ■ #.### Factory setting #.##	Specify the number of decimal places.

Path: Menu/Setup/Inputs/Binary input x:y¹⁾

Function	Options	Info
Input mode	Options <ul style="list-style-type: none"> ■ Frequency ■ Parameter Factory setting Frequency	Frequency Display in Hz in the measuring menu Parameter You subsequently determine the parameter name and unit. These are then displayed in the measuring menu.
Parameter name <i>Input mode= "Parameter"</i>	Free text	Define a name for the parameter, e.g. "flow rate."
Unit of measure <i>Input mode= "Parameter"</i>	Free text	Determine the unit in which your parameter should be displayed, e.g. "l/min."
Lower range value <i>Input mode= "Parameter"</i>	-2000.00 to 0.00 Factory setting 0.00	Your previously defined unit is additionally displayed. The start of measuring range corresponds to a frequency of 0 Hz.
Upper range value <i>Input mode= "Parameter"</i>	0.00 to 10000.00 Factory setting 0.00	The end of measuring range corresponds to the maximum frequency defined above. The displayed unit is the one predefined by you.
Damping	0 to 600 s Factory setting 0 s	The damping generates a floating average curve of the measured value over the specified time.

1) x:y = slot no. : input number

10.5.3 Configuration of binary outputs**Path: Menu/Setup/Outputs/Binary output x:y¹⁾**

Function	Options	Info
Binary output	Options <ul style="list-style-type: none"> ■ Off ■ On Factory setting On	Switching the output on/off
Signal type	Options <ul style="list-style-type: none"> ■ Static signal ■ PFM Factory setting Static signal	Select the signal type. Static signal Comparable to a relay: output of a diagnostic status or a limit contactor PFM You can output a measured value, e.g. the chlorine value or the manipulated variable of a controller. It functions as a "wear-free" switching contact that can be used to activate a dosing pump, for example.

Path: Menu/Setup/Outputs/Binary output x:y¹⁾

Function	Options	Info
<i>Signal type= "PFM"</i>		
Max. frequency	1.00 to 1000.00 Hz Factory setting 1000.00 Hz	Maximum frequency of the PFM output signal Is to equal the maximum possible upper limit of the measuring range.
Meas. value format	Options <ul style="list-style-type: none"> ■ # ■ #.# ■ #.## ■ #.### Factory setting #.##	Specify the number of decimal places.
Source of data	Options <ul style="list-style-type: none"> ■ None ■ Sensor inputs ■ Binary inputs ■ Controller ■ Fieldbus signals ■ Mathematical functions Factory setting None	Source, whose value should be read out as a frequency over the binary output.
Measuring value <i>Source of data = an input</i>	Selection dependent on "Source of data"	"Inputs" = everything except controllers
Actuator type <i>Source of data = a controller</i>	Options <ul style="list-style-type: none"> ■ None ■ Bipolar ■ Unipolar+ ■ Unipolar- Factory setting None	Determines which controller component the connected actuator, e.g. the dosing pump, should trigger. Unipolar+ Part of the manipulated variable that the controller uses to increase the process value Unipolar- For connected actuators that decrease the controlled variable Bipolar "Split range"
Hold behavior	Options <ul style="list-style-type: none"> ■ Freeze ■ Fixed value ■ None Factory setting Freeze	Freeze The device freezes the last value. Fixed value You define a fixed current value that is transmitted at the output. None A hold does not affect this output.
Hold value <i>Hold behavior= "Fixed value"</i>	0 to 100 % Factory setting 0 %	

Path: Menu/Setup/Outputs/Binary output x:y¹⁾

Function	Options	Info
Error behavior	Options <ul style="list-style-type: none"> ■ Freeze ■ Fixed value Factory setting Fixed value	Freeze The device freezes the last value. Fixed value You define a fixed current value that is transmitted at the output.
Error value <i>Error behavior= "Fixed value"</i>	0 to 100 % Factory setting 0 %	
<i>Signal type= "Static signal"</i>		
Function	Options <ul style="list-style-type: none"> ■ None ■ Limit switches ■ Diagnostics message ■ Cleaning Factory setting None	Source for the outputted switching state The following functions depend on the option selected. Function = "None" switches the function off without requiring any settings.
Assignments <i>Function= "Cleaning"</i>	Multiple selection <ul style="list-style-type: none"> ■ Cleaning 1 - Water ... ■ Cleaning 4 - Cleaner 	Here you can decide which binary outputs should be used for activating the valves and pumps. Here you concretely assign a control signal to the binary output for the cleaner/water dosing of a cleaning program. You can define the cleaning programs under: Menu/Setup/Additional functions/Cleaning.
Data sources <i>Function= "Limit switches"</i>	Multiple selection <ul style="list-style-type: none"> ■ Limit switch 1 ... ■ Limit switch 8 	Select the limit contactor to be transmitted over the binary output. The limit switches are configured in the "Setup/Additional functions/Limit switches" menu.
Operating mode <i>Function= "Diagnostics message"</i>	Options <ul style="list-style-type: none"> ■ as assigned ■ Namur M ■ Namur S ■ Namur C ■ Namur F Factory setting as assigned	as assigned With this selection, the diagnosis messages are transmitted over the binary output that you individually allocated to it. Namur M ... F When you choose one of the Namur classes, all messages allocated to that respective class are output. You can also change the Namur class assignment for every diagnostics message. (Menu/Setup/General settings/Diagnostics/Device behavior or Menu/Setup/Inputs/././Diagnostics settings/Diag. behavior)

1) x:y = slot no. : input number

10.6 Additional functions

10.6.1 Limit switch

There are different ways of configuring a limit switch:

- Assigning a switch-on and switch-off point
- Assigning a switch-on and switch-off delay for a relay
- Setting an alarm threshold and also outputting an error message
- Starting a cleaning function

Path: Menu/Setup/Additional functions/Limit switches/Limit switches 1 to 8

Function	Options	Info
Source of data	Options <ul style="list-style-type: none"> ■ None ■ Connected sensors Factory setting None	Specify the input or output which should be the source of data for the limit switch.
Measuring value	Options <ul style="list-style-type: none"> ■ None ■ Depends on theSource of data Factory setting None	The measured value you can select depends on the option selected under "Source of data".

Measured valuedepending on theSource of data

Source of data	Measured value
pH Glass	Options <ul style="list-style-type: none"> ■ Raw value mV ■ pH ■ Temperature
pH ISFET	
ORP	Options <ul style="list-style-type: none"> ■ Temperature ■ ORP mV ■ ORP %
Oxygen (amp.)	Options <ul style="list-style-type: none"> ■ Temperature ■ Partial pressure ■ Concentration liquid ■ Saturation ■ Raw value nA (only Oxygen (amp.)) ■ Raw value µs (only Oxygen (opt. WW))
Oxygen (opt. WW)	
Cond i	Options <ul style="list-style-type: none"> ■ Temperature ■ Conductivity ■ Resistance (only Cond c) ■ Concentration (only Cond i)
Cond c	

Measured value depending on the Source of data

Source of data	Measured value
Chlorine	Options <ul style="list-style-type: none"> ■ Temperature ■ Current ■ Concentration
ISE	Options <ul style="list-style-type: none"> ■ Temperature ■ pH ■ Ammonium ■ Nitrate ■ Potassium ■ Chloride
TU/TS	Options <ul style="list-style-type: none"> ■ Temperature ■ Turbidity g/l ■ Turbidity FNU
Nitrate	Options <ul style="list-style-type: none"> ■ Temperature ■ NO₃ ■ NO₃-N
SAC	Options <ul style="list-style-type: none"> ■ Temperature ■ SAC ■ Transm. ■ Absorption ■ COD ■ BOD
Controller 1	Options <ul style="list-style-type: none"> ■ Bipolar (only current outputs) ■ Unipolar+ ■ Unipolar-
Controller 2	
Mathematical functions	All the mathematical functions can also be used as a data source and the calculated value can be used as the measured value.

 You can monitor the manipulated variable by assigning the controller manipulated variable to a limit switch (e.g. configure a dosing time alarm).

Path: Menu/Setup/Additional functions/Limit switches/Limit switches 1 to 8

Function	Options	Info
Cleaning program	Options <ul style="list-style-type: none"> ■ None ■ Cleaning 1 ■ Cleaning 2 ■ Cleaning 3 ■ Cleaning 4 Factory setting None	Use this function to choose the cleaning instance which should be started when the limit switch is active.

Path: Menu/Setup/Additional functions/Limit switches/Limit switches 1 to 8

Function	Options	Info
Function	Options <ul style="list-style-type: none"> ■ On ■ Off Factory setting Off	Activating/deactivating the limit switch
Operating mode	Options <ul style="list-style-type: none"> ■ Above limit check ■ Below limit check ■ In range check ■ Out of range check ■ Change rate Factory setting Above limit check	Type of limit value monitoring: <ul style="list-style-type: none"> ■ Limit value overshoot or undershoot → <input checked="" type="checkbox"/> 61 ■ Measured value within or outside a range → <input checked="" type="checkbox"/> 62 ■ aChange rate → <input checked="" type="checkbox"/> 64
Limit value	Settings Depends on the measured value	<i>Operating mode="Above limit check" or "Below limit check"</i>

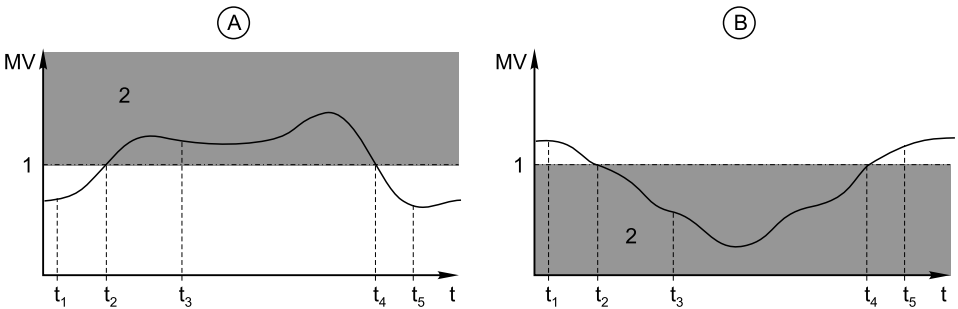

Fig. 61: Exceeding (A) and undershooting (B) a limit value (without hysteresis and switch-on delay)

a0018080

- 1 Limit value
- 2 Alarm range
- t_1, t_3, t_5 No action
- t_2, t_4 An event is generated

- If the measured values (MV) are increasing, the relay contact is closed when the on-value is exceeded ("Limit value" + "Hysteresis") and the start delay has elapsed ("Start delay").
- If the measured values are decreasing, the relay contact is reset when the off-value is undershot ("Limit value" - "Hysteresis") and following the release delay ("Switch off delay").

Path: Menu/Setup/Additional functions/Limit switches/Limit switches 1 to 8

Function	Options	Info
Range lower value	Settings Depends on the measured value	Operating mode="In range check" or "Out of range check"
Range upper value		

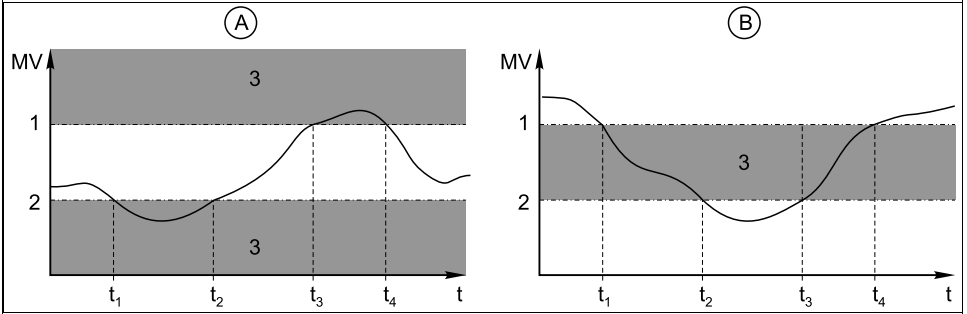

Fig. 62: Monitoring outside (A) and within (B) a range (without hysteresis and switch-on delay)

a0018081

- 1 End of range
- 2 Start of range
- 3 Alarm range
- $t_{1, 2, 3, 4}$ An event is generated

- If the measured values (MV) are increasing, the relay contact is closed when the on-value is exceeded ("Range lower value" + "Hysteresis") and the start delay has elapsed ("Start delay").
- If the measured values are decreasing, the relay contact is reset when the off-value is undershot ("Range upper value" - "Hysteresis") and following the release delay ("Switch off delay").

Hysteresis	Settings Depends on the measured value	Operating mode="In range check", "Out of range check", "Above limit check" or "Below limit check"
------------	--	---

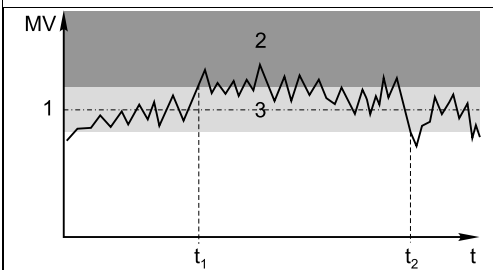

a0018140

Fig. 63: Hysteresis taking the example of limit value overshoot

- 1 Limit value
- 2 Alarm range
- 3 Hysteresis range
- t_1, t_2 An event is generated

The hysteresis is needed to ensure a stable switching behavior.

The device software adds or subtracts the value set here to/from the limit value (Limit value, Range lower value or Range upper value). This results in the double "Hysteresis" value for the hysteresis range around the limit value.

An event is then only generated if the measured value (MV) completely passes through the hysteresis range.

→ 63

Path: Menu/Setup/Additional functions/Limit switches/Limit switches 1 to 8

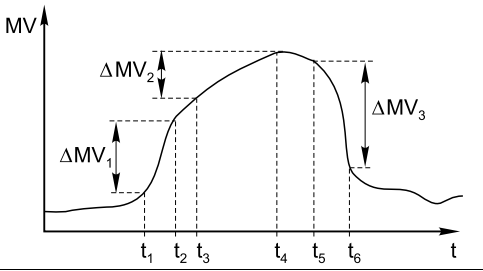
Function	Options	Info
Start delay	0 to 9999 s	<i>Operating mode="In range check", "Out of range check", "Above limit check" or "Below limit check"</i> Synonyms: pick-up and drop-out delay
Switch off delay	Factory setting 0 s	
Delta value	Settings Depends on the measured value	<i>Operating mode="Change rate"</i> The slope of the measured value (MV) is monitored in this mode. An event is generated if, in the given timeframe (Delta time), the measured value increases or decreases by more than the specified value (Delta value). No further event is generated if the value continues to experience such a steep increase or decrease. If the slope is back below the limit value, the alarm status is reset after a preset time (Auto Confirm). Events are triggered by the following conditions in the example given: $t_2 - t_1 < \text{"Delta time" and } \Delta MV_1 > \text{"Delta value"}$ $t_4 - t_3 > \text{"Auto Confirm" and } \Delta MV_2 < \text{"Delta value"}$ $t_6 - t_5 < \text{"Delta time" and } \Delta MV_3 > \Delta MV$
Delta time	00:01 to 23:59 Factory setting 01:00	
Auto Confirm	00:01 to 23:59 Factory setting 00:01	
		

a0018100

Fig. 64: aChange rate

10.6.2 Controller

Controller structure in Laplace representation

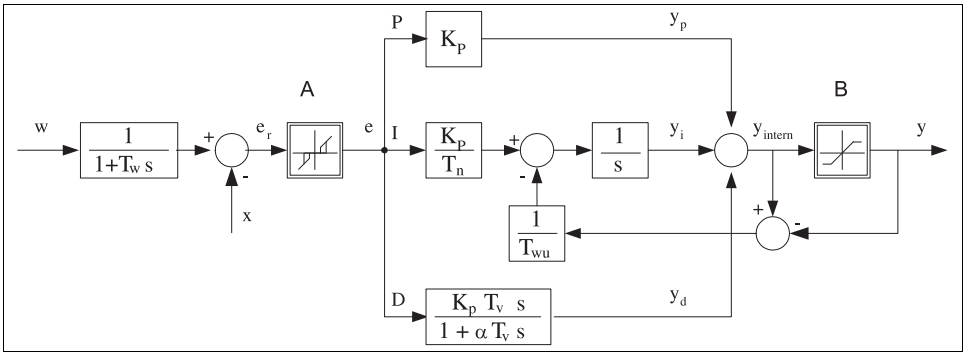

a0015007

Fig. 65: Block diagram of the controller structure

<i>A</i>	Neutral zone	<i>I</i>	Integral value
<i>B</i>	Output limiting	<i>D</i>	Derivative value
K_p	Gain (P-value)	αT_v	Damping time constant with $\alpha=0$ to 1
T_n	Integral action time (I-value)	<i>e</i>	Control deviation
T_n	Derivative action time (D-value)	<i>w</i>	Set point
T_w	Time constant for set point damping	<i>x</i>	Controlled variable
T_{wu}	Time constant for anti-windup feedback	<i>y</i>	Manipulated variable
<i>P</i>	Proportional value		

The controller structure of the device comprises set point damping at the input to prevent erratic changes in the manipulated variable if the set point changes. The difference between the set point *w* and the controlled variable (measured value) *X* results in the control deviation which is filtered by a neutral zone.

The neutral zone is used to suppress control deviations (*e*) that are too small. The control deviation thus filtered is now fed to the actual PID controller which divides into three parts based on the P (proportional), I (integral) and D (derivative) values (top-down). The integral section (middle) also comprises an anti-windup mechanism for limiting the integrator. A low-pass filter is added to the D-section to damp hard D-terms in the manipulated variable. The sum of the 3 sections results in the internal controller manipulated variable which is limited according to the settings (for PID-2s to -100% to +100%).

The graphic does not illustrate a downstream filter for limiting the rate of change of the manipulated variable (can be configured in the menu in "Max Y change rate /s").

 In the menu do not configure the gain K_p . Instead configure the reciprocal value, the proportional band X_p ($K_p=1/X_p$).

Configuration

Make the following decisions when configuring a controller:

1. What type of process can your process be assigned to?
-->Process type
2. Should it be possible to influence the measured variable (controlled variable) in one direction or in both directions?
One-sided or two-sided controller, -->Controller type
3. What should be the controlled variable (sensor, measured value)? -->Controlled variable
4. Do you have a disturbance variable that should be active at the controller output?
-->Disturbance variable
5. Define the parameters for the controller:
 - Setpoint, -->Setpoint
 - Neutral zone, -->Xn
 - Proportional band, -->Xp
 - Integral action time (I-value), -->Tn
 - Derivative action time (D-value), -->Tv
6. What should the controller do in the event of a hold (measured error, sensor replacement, cleaning etc.)?
 - Pause or continue with dosing?
 - At the end of a hold, continue or restart the control loop (affects I-value)?
7. How should the actuator be triggered?
 - Assign "Unipolar+" to the output for an actuator which can increase the measured value.
 - Assign "Unipolar-" to the output for an actuator which can decrease the measured value.
 - Select "Bipolar" if you want to output the manipulated variable via one current output only (split range).
8. Configure the outputs and switch on the controller.

Path: Menu/Setup/Additional functions/Controller 1 or Controller 2

Function	Options	Info
Control	Options <ul style="list-style-type: none"> ■ Off ■ Automatic ■ Manual mode Factory setting Off	First configure the controller and leave the switch at "Off" during this time. Once you have made all the settings, you can assign the controller to an output and switch it on.
▶ Manual mode		
Y	-100 to 100 % Factory setting 0 %	Specify the manipulated variable that should be output in manual mode.
Y Actual output	Read only	Manipulated variable actually output.
Name	Free text	Give the controller a name so you can identify it later on.

Path: Menu/Setup/Additional functions/Controller 1 or Controller 2

Function	Options	Info
Controller Enable	Options <ul style="list-style-type: none"> ■ None ■ Binary inputs ■ Limit switch ■ Fieldbus variables Factory setting None	In connection with the DIO module, you can select a binary input signal, e.g. from an inductive proximity switch, as a source for enabling the controller.
Setup Level	Options <ul style="list-style-type: none"> ■ Standard ■ Advanced Factory setting Standard	The Setup Level changes the number of parameters that can be configured. If you choose "Standard" the other controller parameters are active nevertheless. The system uses the factory settings which usually suffice in most cases.
Process type	Options <ul style="list-style-type: none"> ■ Inline ■ Batch Factory setting Inline	Decide what type of process best describes your particular process (see the explanation below).

Batch process
The medium is in a closed system.
The task of the control system is to dose in such a way that the measured value (controlled variable) changes from its start value to its target value. No more dosing is needed once the setpoint has been reached and the system is stable. If the target value is overshoot, a two-sided control system can compensate for this.
In the case of 2-sided batch control systems, a neutral zone is used/configured to suppress oscillations around the setpoint.

In-line process
In an in-line process, the control system works with the medium flowing by in the process. Here, the controller has the task of using the manipulated variable to set a mixture ratio between the medium and dosing agent such that the resulting measured variable corresponds to the setpoint. The properties and volume of the medium flow can change at any time and the controller has to react to these changes on a continuous basis. If the flow rate and medium remain constant, the manipulated variable can also assume a fixed value once the process has settled. Since the control process is never "finished" here, this type of control is also referred to as continuous control.

 A mixture of both process types can often be found in practice: the semi-batch process. Depending on the ratio between the flow and the container volume, this arrangement behaves either like a batch process or an in-line process.

Path: Menu/Setup/Additional functions/Controller 1 or Controller 2

Function	Options	Info
Controller type	Options <ul style="list-style-type: none"> ■ PID 1-sided ■ PID 2-sided Factory setting PID 2-sided	Depending on the actuator connected, you influence the process in just one direction (e.g. heating) or in both directions (e.g. heating and cooling).

A 2-sided controller can output a manipulated variable in the range from -100% to +100%, i.e. the manipulated variable is bipolar. The manipulated variable is positive if the controller should increase the process value. In the case of a pure P-controller, this means that the value of the controlled variable x is smaller than the setpoint w . On the other hand, the manipulated variable is negative if the process value should be decreased. The value for x is greater than the setpoint w . The following graphic illustrates the relationship $y = (w-x)/X_p$:

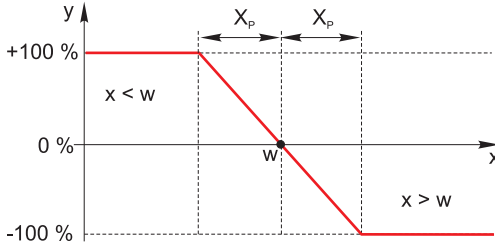

Effective direction <i>Controller type="PID 1-sided"</i>	Options <ul style="list-style-type: none"> ■ Direct ■ Reverse Factory setting Reverse	In what direction should the controller influence the measured value? <ul style="list-style-type: none"> ■ The measured value should increase as a result of dosing (e.g. heating) --> "Reverse" ■ The measured value should decrease as a result of dosing (e.g. cooling) --> "Direct"
---	---	---

A 1-sided controller has a unipolar manipulated variable, i.e. it can only influence the process in one direction. If the controller should increase the process value, set "Reverse" as the effective direction. The controller then becomes active when the process value is too small (range A). With the "Direct" effective direction, the controller acts as a "downwards controller". It becomes active when the process value (e.g. the temperature) is too high (range B).

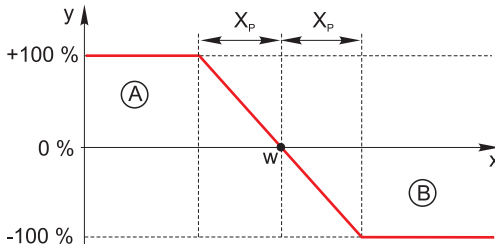

The red curve shows overlap between the curves of the two 1-sided controllers.

Path: Menu/Setup/Additional functions/Controller 1 or Controller 2

Function	Options	Info
▶ Controlled variable		
Source of data	Options <ul style="list-style-type: none"> ■ Sensors ■ Current inputs ■ Fieldbus signals ■ Binary inputs ■ Mathematical functions Factory setting None	Specify the input or output which should be the source of data for the controlled variable.
Measured value	Options <ul style="list-style-type: none"> ■ None ■ Depends on theSource of data Factory setting None	Specify the measured value that should be your controlled variable. The measured value you can select depends on the option selected under "Source of data".
▶ Setpoint		
Setpoint	Range of adjustment and factory setting Depends on the "Source of data"	Not available if a fieldbus has been selected as the "Source of data" Specify the setpoint for the controlled variable.

Path: Menu/Setup/Additional functions/Controller 1 or Controller 2

Function	Options	Info
▶ Disturbance variable		optional, activation code necessary

With "flowing medium" (inline) controls, it can happen that the flow rate is non-constant. In some circumstances, strong fluctuations are possible. In the case of a settled control system in which the flow rate is suddenly halved, it is desirable that the dosed quantity from the controller is also directly halved. In order to achieve this type of "flow-rate-proportional" dosing, this task is not left to the I-component of the controller, but rather one enters the (to be measured) flow rate as disturbance variable z multiplicative at the controller output.

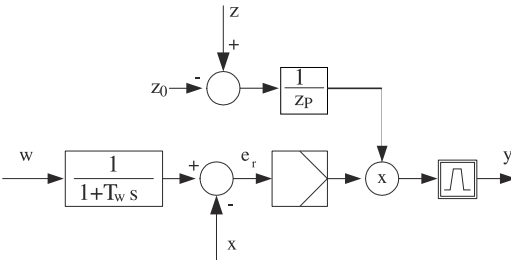

Strictly speaking, feedforward control involves an open-loop control system, since its effect is not measured directly. That means that the feed flow is directed exclusively forward. Hence the designation "feedforward control." For the additive feedforward control that is alternatively available in the device, the (standardized) disturbance variable is added to the controller actuating variable. This enables you to set up a type of variable base load dosing. The standardization of the disturbance variable is required both for multiplicative and for additive feedforward control and is done using parameters Z_0 (zero point) and Z_p (proportional band): $z_n = (z - z_0)/Z_p$

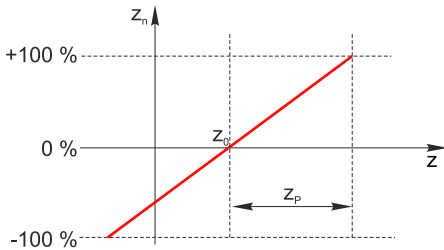

Example:

Flowmeter with measuring range 0 to 200 m³/h
 The controller would currently dose 100% without feedforward control.
 The feedforward control should be configured such that at $z = 200\text{m}^3/\text{h}$, the controller still doses at 100% ($z_n = 1$). If the flow rate drops, the dosing rate should be reduced, and at a flow rate of less than 4 m³/h, dosing should stop entirely ($z_n = 0$).
 --> Select the zero point $z_0 = 4\text{ m}^3/\text{h}$ and the proportional band $Z_p = 196\text{ m}^3/\text{h}$.

Function	Options <input type="checkbox"/> Off <input type="checkbox"/> Multiply <input type="checkbox"/> Add Factory setting Off	Selecting multiplicative or additive feedforward control
----------	--	--

Path: Menu/Setup/Additional functions/Controller 1 or Controller 2

Function	Options	Info
Source of data	Options <ul style="list-style-type: none"> ■ Sensors ■ Current inputs ■ Fieldbus signals ■ Binary inputs ■ Mathematical functions Factory setting None	Specify the input or output which should be the source of data for the disturbance variable.
Measured value	Options <ul style="list-style-type: none"> ■ None ■ Depends on theSource of data Factory setting None	Specify the measured value that should be your disturbance variable. The measured value you can select depends on the option selected under "Source of data".
Zp	Range of adjustment depending on the selection of the measured value	Proportional band -->
Z0		Zero point
<p>► Parameters</p> <p>The Liquiline PID controller has been implemented in the serial structural form, i.e. it has the following parameters:</p> <ul style="list-style-type: none"> ■ Integral action time T_n ■ Derivative action time T_v ■ Proportional band X_p <p>You can also configure the following for Setup Level="Advanced":</p> <ul style="list-style-type: none"> ■ Time constant T_{wu} ■ Time constant Alpha ■ Width of the neutral zone X_n ■ Width of the hysteresis range of the neutral zone X_{hyst} ■ Cycle time of the controller 		
T_n	0.0 to 9999.0 s Factory setting 0.0 s	The integral action time specifies the effect of the I-value If $T_n > 0$, then the following holds true: Clock < $T_{wu} < 0.5(T_n + T_v)$
<p>The integral action time is the time needed in a step-function response to achieve a change in the manipulated variable - as a result of the I effect - which has the same magnitude as the P-value.</p> <p>$e = \text{control deviation, } e = w - x \text{ (setpoint controlled variable)}$</p>		

Path: Menu/Setup/Additional functions/Controller 1 or Controller 2

Function	Options	Info
Twu	0.1 to 999.9 s Factory setting 20.0 s	Time constant for anti-windup feedback The lower the value the greater the integrator inhibition. Exercise extreme caution when making changes. $Clock < Twu < 0.5(Tn + Tv)$
Tv	0.0 to 9999.0 s Factory setting 0.0 s	The derivative action time specifies the effect of the D-value

The derivative action time is the time by which the ramp response of a PD controller reaches a specific value of the manipulated variable at an earlier stage than it would solely as a result of its P-value.

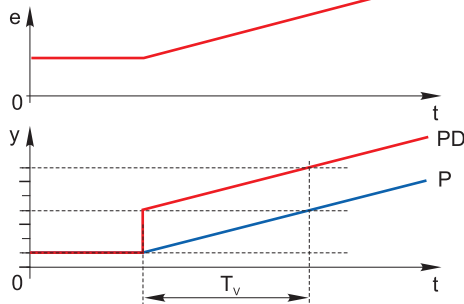

alpha	0.0 to 1.0 Factory setting 0.3	Affects the additional damping filter of the D-controller. The time constant is calculated from $\alpha * Tv$.
Process balance <i>Controller type="PID 2-sided"</i>	Options <ul style="list-style-type: none"> ■ Symmetric ■ Asymmetric Factory setting Symmetric	Symmetric There is only one control gain and this applies for both sides of the process. Asymmetric You can set the control gain individually for both sides of the process.
Xp <i>Process balance="Symmetric"</i>	Range of adjustment and factory setting Depends on the "Source of data"	Proportional band, reciprocal value of the proportional gain K_p As soon as X deviates more than X_p from the set point, Y reaches 100%.
Xp Low	Range of adjustment and factory setting Depends on the "Source of data"	<i>Process balance="Asymmetric"</i>
Xp High		

Path: Menu/Setup/Additional functions/Controller 1 or Controller 2

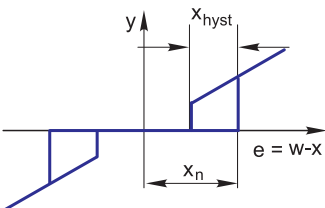
Function	Options	Info
Xn <i>Process balance="Symmetric"</i>	Range of adjustment and factory setting Depends on the "Source of data"	Tolerance range about the setpoint that prevents minor oscillations about the setpoint if using two-sided control loops.
XN Low	Range of adjustment and factory setting Depends on the "Source of data"	<i>Process balance="Asymmetric"</i>
XN High		
XHyst	0.0 to 99.9 % Factory setting 0.0 %	Width of the hysteresis range of the neutral zone, relative component of Xn
 <p>The graphic illustrates the manipulated variable (with a pure P-controller) over the control deviation e (set point minus controlled variable). Very low control deviations are set to zero. Control deviations $> X_n$ are processed "in the normal way". Via X_{hyst} it is possible to configure a hysteresis to suppress oscillations at the edges.</p>		
Clock	0.333 to 100.000 s Factory setting 1.000 s	Expert setting! Only change the cycle time of the controller if you know exactly what you are doing! Clock < Twu < 0.5(Tn + Tv)
Max Y change rate /s	0.00 to 1.00 Factory setting 0.40	Limits the change of the output variable
▶ Hold behavior		Hold=measured value is no longer reliable
Manipulated Variable	Options <ul style="list-style-type: none"> ■ Freeze ■ Set to zero Factory setting Freeze	How should the controller react to a measured value that is no longer reliable? Freeze The manipulated variable is frozen at the current value Set to zero Manipulated variable is set to 0 (no dosing)
State	Options <ul style="list-style-type: none"> ■ Freeze ■ Reset Factory setting Freeze	Internal controller status Freeze No change Reset After a hold, the control system starts from scratch, and settling time takes place again.

Path: Menu/Setup/Additional functions/Controller 1 or Controller 2

Function	Options	Info
▶ Manual mode		
Y	-100 to 100 % Factory setting 0 %	Editable manipulated variable, which is output in the manual mode.
Y Actual output	Read only	Manipulated variable actually output: Input manually for "Control" = "Manual mode", calculated by the controller for Control" = "Automatic"
Setpoint	Read only	Configured setpoint (damped) If the controller is running and the set point is reconfigured, here you can see how the (effective) set point gradually moves towards the new value.
X		Current measured value
▶ Output selection		Goes to the "Outputs" menu --> "Outputs" section

10.6.3 Cleaning programs

⚠ CAUTION

The cleaning system is not switched off during calibration or maintenance activities

Risk of injury due to medium or cleaning agent

- ▶ If a cleaning system is connected, switch it off before removing a sensor from the medium.
- ▶ If you are not switching off the cleaning system because you wish to test the cleaning function, wear protective clothing, goggles and gloves or take other appropriate measures.

Selecting the cleaning type

1. Select a cleaning program in the menu Setup/Additional functions/Cleaning.
 - ↳ You can configure 4 different types of cleaning which you can assign individually to the inputs.
2. For each cleaning program use the "Cleaning type" to decide which type of cleaning should be performed.

The user can choose from the following cleaning types:

- Standard clean
- Chemoclean
- Chemoclean Plus

i Under "State of cleaning" you can see whether the cleaning program is active or not. This is for information purposes only.

Standard cleaning

Standard cleaning involves cleaning a sensor with compressed air, for instance, as performed with the ion-selective sensor CAS40D (connection of the cleaning unit for CAS40D → 33).

Path: Menu/Setup/Additional functions/Cleaning/Cleaning 1 ... 4/Standard clean

Function	Options	Info
Cleaning time	5 to 600 s Factory setting 10 s	Cleaning time... Cleaning duration The cleaning duration and interval depend on the process and sensor. Determine the variables empirically or based on experience.

Defining the cleaning cycle → 102

Chemoclean

An example of the use of the "Chemoclean" function is the use of the CYR10 injector unit to clean pH glass sensors. (CYR10 connection → 34)

Path: Menu/Setup/Additional functions/Cleaning/Cleaning 1 ... 4/Chemoclean

Function	Options	Info
Cleaning time	0 to 900 s Factory setting 5 s	Cleaning duration The cleaning duration, pre-rinse and post-rinse times and the interval depend on the process and sensor. Determine the variables empirically or based on experience.
Prerinse time	0 to 900 s Factory setting 0 s	
Postrinse time	0 to 900 s Factory setting 0 s	

Chemoclean Plus

Use the "Chemoclean Plus" function for measuring cycles in aggressive media or for regular cleaning operations with acids, bases or special cleaners.

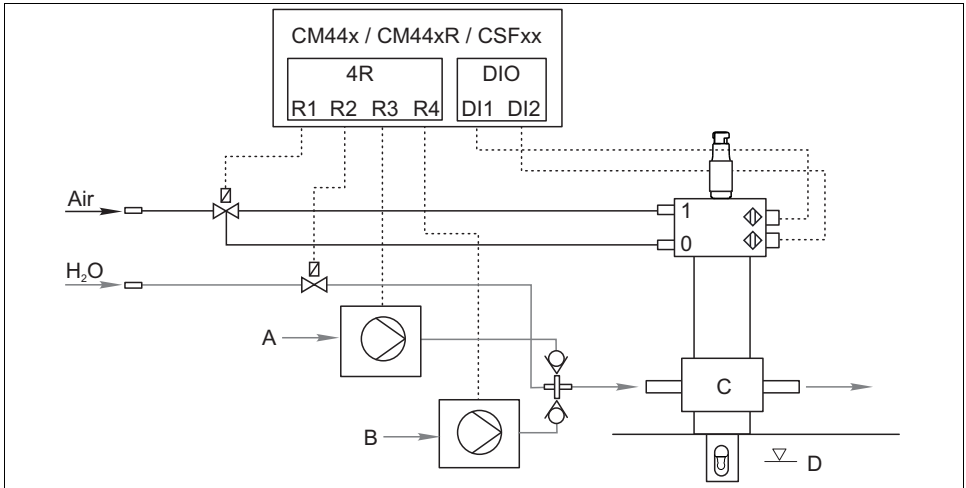

Fig. 66: Layout of a measuring point with regular cleaning with acid and base

a0022102

- 0 Compressed air connection for "Measure" assembly
- 1 position
- A Compressed air connection for "Service" assembly position
- Acid pump
- B Base pump
- C Rinse chamber of assembly ("Service" position)
- D Medium ("Measure" position)

Path: Menu/Setup/Additional functions/Cleaning/Cleaning 1 ... 4/Chemoclean Plus/ChemoCleanPlus setup

Function	Options	Info
Cleaning steps setup	Table to create a time program	You define a maximum of 30 program steps which should be performed one after the other. For each step enter the duration [s] and the state (0="off", 1="on") of each relay or output. You can specify the number and name of the outputs further down in the menu. See below for program examples.
Failsafe step setup	Table view	In the table specify the states that the relays or outputs should assume in the event of an error.
Limit contacts	0 to 2	Select the number of digital input signals (e.g. from limit position switches of the retractable assembly).
Limit contact 1 ... 2	Options <ul style="list-style-type: none"> ■ Binary inputs ■ Fieldbus signals 	Define the signal source for each limit position switch.
Outputs	0 to 4	Select the number of outputs that actuators, such as valves or pumps, should activate.

Path: Menu/Setup/Additional functions/Cleaning/Cleaning 1 ... 4/Chemoclean Plus/ChemoCleanPlus setup

Function	Options	Info
Output label 1 ... 4	Text	You can assign a meaningful name to each output, e.g. "assembly", "acid", "base" etc.

Sample program: regular cleaning with acid and base

Limit switch	Duration [s]	Assembly	Water	Acid	Base
ES1 0 (Assembly in "Measure" position)	1	0	0	0	0
ES1 1 (Assembly in "Service" position)	5	1	0	0	0
ES1 1	10	1	1	0	0
ES1 1	2	1	1	1	0
ES1 1	10	1	1	0	0
ES1 1	2	1	1	0	1
ES1 1	10	1	1	0	0
ES1 1	2	1	0	0	0
ES1 0	5	0	0	0	0

The pneumatic retractable assembly, e.g. CPA875, is activated by compressed air via a two-way valve. As a result, the assembly assumes either the position 0 ("Measure" - sensor in medium) or position 1 ("Service" - sensor in rinse chamber). Media such as water, acids or bases are supplied via valves or pumps. Here there are two states: 0 (= "off" or "closed") and 1 (= "on" or "open").



The hardware required for "Chemoclean Plus", such as control valves, pumps, compressed air supply, media etc., must be provided by the customer.

Defining the cleaning cycle

Path: Menu/Setup/Additional functions/Cleaning/Cleaning 1 ... 4

Function	Options	Info
Cleaning cycle	Options <ul style="list-style-type: none"> ■ Off ■ Interval ■ Weekly program Factory setting Off	Choose from a cleaning routine that is restarted at set intervals and a user-definable weekly program.
<i>Cleaning cycle= "Interval"</i>		
Cleaning interval	00-00:01 to 07-00:00 (DD-hh:mm) Factory setting 01-00:00	The interval value can be between 1 minute and 7 days. Example: You have set the value "01-00:00". Each day, the cleaning cycle starts at the same time you started the first cleaning cycle.
<i>Cleaning cycle= "Weekly program"</i>		
▶ Daily event times	00:00 to 23:59 (HH:MM)	<ol style="list-style-type: none"> 1. "Event time 1 to 6": Define up to 6 times. <ul style="list-style-type: none"> ↳ You can then choose from these for each weekday afterwards. 2. For each day of the week, individually choose which of the 6 times is to be used for a cleaning routine on this particular day. <p>In this way you create weekly programs that are perfectly adapted to suit your process.</p>
▶ Weekdays	Monday ... Sunday	

Other settings and manual cleaning

Path: Menu/Setup/Additional functions/Cleaning/Cleaning 1 ... 4

Function	Options	Info
Start signal	Options <ul style="list-style-type: none"> ▪ Bus signals ▪ Signals of digital or analog inputs Factory setting None	In addition to cyclic cleaning, you can also use an input signal to start event-controlled cleaning. Choose the trigger for such a cleaning process here. Interval programs and weekly programs are executed as normal, i.e. conflicts can occur. Priority is given to the cleaning program that was the first to be started.
Hold	Options <ul style="list-style-type: none"> ▪ On ▪ Off Factory setting On	Decide whether there should be a hold during the cleaning process. This hold affects the inputs to which this cleaning process is assigned.
▷ Start single	Action	Start an individual cleaning process with the selected parameters. If cyclical cleaning is enabled, there are times in which it is not possible to manually start the process.
▷ Manual mode	Action	You start the manual mode by acknowledging the warning. You can now start each possible cleaning step manually. If you want to return to cyclic cleaning, you must set "Manual mode" to "Off".
▷ StoporStop Failsafe	Action	End the cleaning process (cyclically or manually)
▶ Output selection		Goes to the "Outputs" menu You can assign the cleaning program directly to one or more outputs. --> "Outputs" section

10.6.4 Mathematical functions

In addition to "real" process values which are delivered by analog inputs or physical sensors connected to the device, you can also calculate a maximum of 6 "virtual" process values using mathematical functions.

The "virtual" process values can be:

- Output via a current output or a fieldbus
- Used as a controlled variable
- Assigned as a measured variable to a limit contactor
- Used as a measured variable to trigger cleaning
- Displayed in user-defined measuring menus.

Difference

You can subtract the measured values of two sensors and use the result to detect incorrect measurements, for example.

To calculate a difference, you must use two measured values with the same engineering unit.

Path: Menu/Setup/Additional functions/Mathematical functions/MF 1 to 6/Mode/Difference

Function	Options	Info
Calculation	Options <ul style="list-style-type: none"> ■ Off ■ On Factory setting Off	On/off switch for the function
Y1	The options depend on the sensors connected	Select the sensors and the measured variables that should be used as the minuend (Y1) or subtrahend (Y2).
Measured value		
Y2		
Measured value		
Difference value	Read only	View this value in a user-defined measuring screen or output the value via the current output.

Redundancy

Use this function to monitor two or three sensors with redundant measurements. The arithmetic average of the two closest measured values is calculated and output as the redundancy value.

Path: Menu/Setup/Additional functions/Mathematical functions/MF 1 to 6/Mode/Redundancy

Function	Options	Info
Calculation	Options <ul style="list-style-type: none"> ■ Off ■ On Factory setting Off	On/off switch for the function
Y1	The options depend on the sensors connected	You can select different types of sensor that output the same measured value. Example for temperature redundancy: You have a pH sensor and an oxygen sensor at inputs 1 and 2. Select both as "Y1" and "Y2". For "Measured value" select the temperature.
Measured value		
Y2		
Measured value		
Y3 (optional)		
Measured value		
Deviation control	Options <ul style="list-style-type: none"> ■ Off ■ On Factory setting Off	You can monitor the redundancy. Specify an absolute limit value that may not be exceeded.
Deviation limit	Depends on the selected measured value	
Redundancy	Read only	View this value in a user-defined measuring screen or output the value via the current output.

rH value

To calculate the rH value, a pH sensor and an ORP sensor must be connected. It is irrelevant whether you are using a pH glass sensor, an ISFET sensor or the pH electrode of an ISE sensor.

Path: Menu/Setup/Additional functions/Mathematical functions/MF 1 to 6/Mode/rH calculation

Function	Options	Info
Calculation	Options <ul style="list-style-type: none"> ■ Off ■ On Factory setting Off	On/off switch for the function
pH source	Connected pH sensor	Set the input for the pH sensor and the input for the ORP sensor. Measured value interrogation is obsolete as you must select pH or ORP mV.
ORP source	Connected ORP sensor	
Calculated rH	Read only	View this value in a user-defined measuring screen or output the value via the current output.

Degassed conductivity

Carbon dioxide from the air can be a contributing factor to the conductivity of a medium. The degassed conductivity is the conductivity of the medium excluding the conductivity caused by carbon dioxide.

In the power station industry, for example, it is advantageous to use the degassed conductivity:

- The percentage of conductivity caused by corrosion products or fouling in the feed water can be determined as early as when the turbines are started. The system excludes the initially high conductivity values resulting from the ingress of air.
- If carbon dioxide is regarded as non-corrosive, the live steam can be directed to the turbine far earlier during startup.
- If the conductivity value increases during normal operation, it is possible to immediately determine an ingress of coolant or air by calculating the degassed conductivity.

Path: Menu/Setup/Additional functions/Mathematical functions/MF 1 to 6/Mode/Degassed conductivity

Function	Options	Info
Calculation	Options <ul style="list-style-type: none"> ■ Off ■ On Factory setting Off	On/off switch for the function
Cation conductivity	Connected conductivity sensor	"Cation conductivity" is the sensor downstream from the cation exchanger and upstream from the "degassing module", "Degassed conductivity" is the sensor at the outlet of the degassing module. Measured value interrogation is obsolete as you can only choose conductivity.
Degassed conductivity	Connected conductivity sensor	

Path: Menu/Setup/Additional functions/Mathematical functions/MF 1 to 6/Mode/Degassed conductivity

Function	Options	Info
CO2 concentration	Read only	View this value in a user-defined measuring screen or output the value via the current output.

Dual conductivity

You can subtract two conductivity values and use the result, for example, to monitor the efficiency of an ion exchanger.

Path: Menu/Setup/Additional functions/Mathematical functions/MF 1 to 6/Mode/Dual conductivity

Function	Options	Info
Calculation	Options <ul style="list-style-type: none"> ▪ Off ▪ On Factory setting Off	On/off switch for the function
Inlet	The options depend on the sensors connected	Select the sensors that should be used as the minuend (Inlet, e.g. sensor upstream from the ion exchanger) and subtrahend (Outlet, e.g. sensor downstream from the ion exchanger).
Measured value		
Outlet		
Measured value		
Main value format	Options <ul style="list-style-type: none"> ▪ Auto ▪ # ▪ #.# ▪ #.## ▪ #.### Factory setting Auto	
Cond. unit	Options <ul style="list-style-type: none"> ▪ Auto ▪ $\mu\text{S}/\text{cm}$ ▪ mS/cm ▪ S/cm ▪ $\mu\text{S}/\text{m}$ ▪ mS/m ▪ S/m Factory setting Auto	
Dual conductivity	Read only	View this value in a user-defined measuring screen or output the value via the current output.

Calculated pH value

The pH value can be calculated from the measured values of two conductivity sensors under certain conditions. Areas of application include power stations, steam generators and boiler feedwater.

Path: Menu/Setup/Additional functions/Mathematical functions/MF 1 to 6/Mode/pH calculation from conductivity

Function	Options	Info
Calculation	Options <ul style="list-style-type: none"> ■ Off ■ On Factory setting Off	On/off switch for the function
Method	Options <ul style="list-style-type: none"> ■ NaOH ■ NH3 ■ LiOH Factory setting NaOH	The calculation is performed on the basis of Guideline VGB-R-450L of the Technical Association of Large Power Plant Operators (Verband der Großkesselbetreiber, (VGB)). NaOH $\text{pH} = 11 + \log \{(\kappa_v - 1/3 \kappa_n)/273\}$ NH3 $\text{pH} = 11 + \log \{(\kappa_v - 1/3 \kappa_n)/243\}$ LiOH $\text{pH} = 11 + \log \{(\kappa_v - 1/3 \kappa_n)/228\}$ κ_v ... "Inlet" ... direct conductivity κ_n ... "Outlet" ... acid conductivity
Inlet	Choice of conductivity sensor	Inlet
Outlet		Sensor upstream from the cation exchanger, "direct conductivity" Outlet Sensor downstream from the cation exchanger, "acid conductivity" The choice of measured value is obsolete since it must always be "Conductivity".
Calculated pH	Read only	View this value in a user-defined measuring screen or output the value via the current output.

10.6.5 Measuring range switch

A measuring range switching (MRS) configuration includes the following options for each of the four binary input states:

- Mode of operation (conductivity or concentration)
- Concentration table
- Temperature compensation
- Current output turndown
- Limit contactor range

If an MRS set is assigned to a channel and MRS is enabled for this set, the measuring range configuration selected via the binary inputs is used instead of the normal configuration of the linked sensor channel. So that the current outputs and limit contactors are controlled by the MRS, these must be linked with the MRS set, not with the measuring channel.

Current outputs and limit contactors that are connected to an MRS set receive the measured value corresponding to the mode of operation as well as the corresponding turndown or range for limit value monitoring. A limit contactor connected to an MRS set always uses the "Out of range check" mode, i.e. it switches if the value is outside the configured range. If a current output or limit contactor is connected to an MRS set, the turndown, monitoring range and limit contactor mode can no longer be configured manually. Therefore, these options are hidden in the current output menu and limit contactor menu.

Example: CIP cleaning in a brewery

	Beer	Water	Base	Acid
Binary input 1	0	0	1	1
Binary input 1	0	1	0	1
	Measuring range 00	Measuring range 01	Measuring range 10	Measuring range 11
Operating mode	Conductivity	Conductivity	Concentration	Concentration
Conc. Table	-	-	NaOH 0..15%	User table 1
Compensation	User table 1	Linear	-	-
Current output				
Range lower value	1.00 mS/cm	0.1 mS/cm	0.50 %	0.50 %
Range upper value	3.00 mS/cm	0.8 mS/cm	5.00 %	1.50 %
Limit switches				
Range lower value	2.3 mS/cm	0.5 mS/cm	2.00 %	1.30 %
Range upper value	2.5 mS/cm	0.7 mS/cm	2.10 %	1.40 %

Path: Menu/Setup/Additional functions/Measuring range switch

Function	Options	Info
<ul style="list-style-type: none"> ▶ MRS set 1 ▶ MRS set 2 		If you enter both activation codes, you have two independent parameter sets available for measuring range switching. The submenus are the same for both sets.
MRS	Options <ul style="list-style-type: none"> ▪ On ▪ Off Factory setting Off	Switches the function on or off
Sensor	Options <ul style="list-style-type: none"> ▪ None ▪ Connected, inductive conductivity sensors Factory setting None	This function can be used on conductivity sensors only.
Binary input 1	Options <ul style="list-style-type: none"> ▪ None ▪ Binary inputs ▪ Fieldbus signals ▪ Limit switch Factory setting None	Source of the switching signal, can be selected for input 1 and 2 in each case
Binary input 2		
<i>Sensor = conductivity sensor</i>		
<ul style="list-style-type: none"> ▶ Measuring range 00 ▶ Measuring range 01 ▶ Measuring range 10 ▶ Measuring range 11 		Select the MRSs; a maximum of 4 are possible. The submenus are identical for each and thus are displayed only once.
Operating mode	Options <ul style="list-style-type: none"> ▪ Conductivity ▪ Concentration Factory setting Conductivity	

Path: Menu/Setup/Additional functions/Measuring range switch

Function	Options	Info
Conc. Table	Options <ul style="list-style-type: none"> ■ NaOH 0..15% ■ HCl 0..20% ■ HNO₃ 0..25% ■ HNO₃ 24..30% ■ H₂SO₄ 0..28% ■ H₂SO₄ 40..80% ■ H₂SO₄ 93..100% ■ H₃PO₄ 0..40% ■ NaCl 0..26% ■ User table 1 ■ User table 2 ■ User table 3 ■ User table 4 Factory setting NaOH 0..15%	Concentration tables saved at the factory: NaOH: 0 to 15%, 0 to 100 °C (32 to 212 °F) HCl: 0 to 20%, 0 to 65 °C (32 to 149 °F) HNO ₃ : 0 to 25%, 2 to 80 °C (36 to 176 °F) H ₂ SO ₄ : 0 to 28%, 0 to 100 °C (32 to 212 °F) H ₂ SO ₄ : 40 to 80%, 0 to 100 °C (32 to 212 °F) H ₂ SO ₄ : 93 to 100%, 0 to 100 °C (32 to 212 °F) H ₃ PO ₄ : 0 to 40%, 2 to 80 °C (36 to 176 °F) NaCl: 0 to 26%, 2 to 80 °C (36 to 176 °F)
Compensation	Options <ul style="list-style-type: none"> ■ None ■ Linear ■ NaCl (IEC 746-3) ■ Water ISO7888 (20°C) ■ Water ISO7888 (25°C) ■ UPW NaCl ■ UPW HCl ■ User table 1 ■ User table 2 ■ User table 3 ■ User table 4 Factory setting Linear	Various methods are available to compensate for the temperature dependency. Depending on your process, decide which type of compensation you want to use. Alternatively, you can also select "None" and thus measure uncompensated conductivity.
► Current output		
Range lower value	0 to 100 %	<i>Operating mode= "Concentration"</i>
Range upper value		
Range lower unit	Options <ul style="list-style-type: none"> ■ S/m ■ µS/cm ■ mS/cm ■ S/cm ■ µS/m ■ mS/m Factory setting mS/cm	<i>Operating mode= "Conductivity"</i> Define the units and range limits for the output values.
Range lower value	Enter value	
Range upper unit	Enter value	
Range upper value	Enter value	

Path: Menu/Setup/Additional functions/Measuring range switch

Function	Options	Info
▶ Limit switches		
Range lower value	0 to 100 %	<i>Operating mode= "Concentration"</i>
Range upper value		
Range lower unit	Options <ul style="list-style-type: none"> ▪ S/m ▪ μS/cm ▪ mS/cm ▪ S/cm ▪ μS/m ▪ mS/m Factory setting mS/cm	<i>Operating mode= "Conductivity"</i> Define the units and range limits for the output values.
Range lower value	Enter value	
Range upper unit	Selection and factory setting as for "Range lower unit"	
Range upper value	Enter value	

11 Diagnostics and troubleshooting

The color of the display background changes to red if a diagnostics message for error category "F" occurs.

11.1 General troubleshooting

11.1.1 Troubleshooting

A diagnostic message appears on the display or via the fieldbus, measured values are not plausible, or you identify a fault.

1. See the Diagnostics menu for the details on the diagnostic message.
 - ↳ Follow the instructions to rectify the problem.
2. If this does not help: Search for the diagnostic message under "Overview of diagnostic information" (→  118) in this manual. Use the message number as a search criterion. Ignore the letters indicating the Namur error category.
 - ↳ Follow the troubleshooting instructions provided in the last column of the error tables.
3. If the measured values are implausible, the onsite display is faulty or you encounter other problems, search for the faults under "Process errors without messages" or "Device-specific errors".
 - ↳ Follow the recommended measures.
4. Contact the Service Department if you cannot rectify the error yourself. Only cite the error number.

11.1.2 Process errors without messages

See Operating Instructions for "Memosens", BA01245C

11.1.3 Device-specific errors

Problem	Possible cause	Tests and/or remedial measures
Dark display (only with optional display)	No supply voltage	Check if supply voltage applied.
	Display connector plugged in incorrectly	Check. Must be in RJ45 socket on base module.
	Base module defective	Replace base module
Values appear on display but: – Display does not change and / or – Device cannot be operated	Module not wired correctly	Check modules and wiring.
	Impermissible operating system condition	Switch off device and switch it on again.
Implausible measured values	Inputs defective	First perform tests and take measures as outlined in "Process-specific errors" section Measuring input test: – Connect the Memocheck Sim CYP03D to the input and use this to test its function.
Current output, incorrect current value	Incorrect adjustment	Check with integrated current simulation, connect mA meter directly to current output.
	Load too large	
	Shunt / short to ground in current loop	
No current output signal	Base module defective	Check with integrated current simulation, connect mA meter directly to current output.

11.2 Diagnostic information on the local display (optional)

Up-to-date diagnostic events are displayed along with their status category, diagnostic code and short text. Clicking on the Navigator lets you retrieve more information and tips on remedial measures.

11.3 Diagnostic information via web browser

The same information as for the onsite display is available via the web server.

11.4 Diagnostic information via fieldbus

Diagnostic events, status signals and more information are transmitted according to the definitions and technical capability of the respective fieldbus systems

11.5 Adjusting diagnostic information

11.5.1 Classification of diagnostics messages

More detailed information on the current diagnostics messages displayed is provided in the DIAG/Diagnostics list menu.

In accordance with Namur specification NE 107, the diagnostics messages are characterized by:

- Message number
 - Error category (letter in front of the message number)
 - **F** = (Failure) a malfunction has been detected
 - **M** = (Maintenance required) Action should be taken as soon as possible
 - **C** = (Function check) (No error)
Maintenance work is being performed on the device. Wait until the work has been completed.
 - **S** = (Out of specification) The measuring point is being operated outside its specification
Operation is still possible. However, you run the risk of increased wear, shorter operating life or lower accuracy levels. The cause of the problem is to be found outside the measuring point.
 - Message text
-  If you contact the Service Department, please cite the message number only. Since you can individually change the assignment of an error to an error category, the Service Department cannot use this information.

11.5.2 Adjusting diagnostic behavior

All the diagnostics messages are assigned to specific error categories at the factory. Since other settings might be preferred depending on the application, error categories and the effect errors have on the measuring point can be configured individually. Furthermore, every diagnostics message can be disabled.

Example

The controller returns diagnostics message 531 "Logbook full". You want to change this message so that an error is not indicated on the display for example.

1. Go to:
 - Menu/Setup/General settings/Extended setup/Diagnostics/Device behavior for device-specific diagnostics messages (as in this example)
 - Menu/Setup/Inputs/<sensor type>/Extended setup/Diagnostics settings/Diag. behavior for sensor-specific diagnostics messages.
2. Select the diagnostics message and press the navigator button.
3. Decide:
 - a. Should the message be deactivated?
 - b. Do you want to change the error category?
 - c. Should an error current be output?
 - d. Do you want to trigger a cleaning program?
4. Deactivate the message, for example (Diagnostics message to "Off").

Configuration options

The list of diagnostic messages displayed depends on the path selected. There are device-specific messages, and messages that depend on what sensor is connected.

Path: ... /Extended setup/Diagnostics settings/Diag. behavior

Function	Options	Info
List of diagnostic messages		Select the message to be changed. Only then can you make the settings for this message.
Diag. code	Read only	
Diagnostic message	Options <ul style="list-style-type: none"> ▪ On ▪ Off Factory setting Depends on the message	You can deactivate or reactivate a diagnostics message here. Deactivating means: <ul style="list-style-type: none"> ▪ No error message in the measuring mode ▪ No error current at the current output
Error current	Options <ul style="list-style-type: none"> ▪ On ▪ Off Factory setting Depends on the message	Decide whether an error current should be output at the current output if the diagnostic message display is activated.

Path: ... /Extended setup/Diagnostics settings/Diag. behavior

Function	Options	Info
Status signal	Options <ul style="list-style-type: none"> ▪ Maintenance (M) ▪ Out of specification (S) ▪ Function check (C) ▪ Failure (F) Factory setting Depends on the message	The messages are divided into different error categories in accordance with NAMUR NE 107. Decide whether you want to change a status signal assignment for your application.
Diag. output	Options <ul style="list-style-type: none"> ▪ None Factory setting None	Before you can assign the message to an output, you must first configure a relay output to "Diagnostics" (Menu/Setup/Outputs, assign the "Diagnostics" function and set the Operating mode to "as assigned").
Cleaning program (for sensors)	Options <ul style="list-style-type: none"> ▪ None ▪ Cleaning 1 ▪ Cleaning 2 ▪ Cleaning 3 ▪ Cleaning 4 Factory setting None	Decide whether the diagnostic message should trigger a cleaning program. You can define the cleaning programs under: Menu/Setup/Additional functions/Cleaning.
Detail information	Read only	Here you can find more information on the diagnostic message and instructions on how to resolve the problem.

11.6 Overview of diagnostic information

11.6.1 Device-specific, general diagnostics messages

No.	Message	Factory settings			Tests or remedial measures
		Cat.	Diag. on/off	Error current	
202	Selftest active	F	On	Off	Wait for self-test to be finished
216	Hold active	C	On	Off	Output values and status of the channel are on hold
241	Device error	F	On	On	Internal device error 1. Update the software 2. Contact the Service Department 3. Replace the backplane (Service)
242	Software incomp.	F	On	On	
243	Device error	F	On	On	
261	Electr. module	F	On	On	Electronics module defective 1. Replace the module 2. Contact the Service Department
263	Electr. module	F	On	On	Wrong kind of electronics module 1. Replace the module 2. Contact the Service Department
284	Firmware update	M	On	Off	Update completed successfully
285	Update error	F	On	On	Firmware update failed 1. Repeat update 2. SD card error --> use another card 3. Incorrect firmware --> repeat with suitable firmware 4. Contact the Service Department
302	Battery low	M	On	Off	Buffer battery of real time clock is low The date and time are lost if the power is interrupted. --> Contact the Service Department (battery replacement)
304	Module data	F	On	On	At least 1 module has incorrect configuration data 1. Check the system information 2. Contact the Service Department
305	Power consum.	F	On	On	Total power consumption too high 1. Check installation 2. Remove sensors/modules
306	Software error	F	On	On	Internal firmware error --> Contact the Service Department
370	Intern. Voltage	F	On	On	Internal voltage outside the valid range --> Check supply voltage
373	Electr. temp.	M	On	Off	High electronics temperature --> Check ambient temperature and energy consumption

No.	Message	Factory settings			Tests or remedial measures
		Cat.	Diag. on/off	Error current	
374	Sensor check	F	On	Off	No measurement signal from sensor -> Check the sensor connection -> Check sensor, replace if necessary
401	Reset to default	F	On	On	Factory reset is performed
406	Param. active	C	Off	Off	--> Wait for configuration to be finished
407	Diag. active	C	Off	Off	--> Wait for maintenance to be finished
412	Writing backup	F	On	Off	--> Wait for the write process to be finished
413	Reading backup	F	On	Off	--> Wait
460	Curr. under-run	S	On	Off	Reasons
461	Current exceeded	S	On	Off	<ul style="list-style-type: none"> ■ Sensor in air ■ Air pockets in assembly ■ Sensor fouled ■ Incorrect flow to sensor Measures <ol style="list-style-type: none"> 1. Check sensor installation 2. Clean the sensor 3. Adjust assignment of current outputs
462	Output Deviation	S	On	Off	When the current output is read back, the value deviates from the target value displayed. Possible reasons: Current load outside specification, short-circuit or open current loop, module defective <ol style="list-style-type: none"> 1. Check installation of current loop 2. Check module 3. Contact the Service Department
502	No text catalog	F	On	On	--> Contact the Service Department
503	Language change	M	On	Off	Language change failed --> Contact the Service Department
530	Logbook at 80%	M	On	Off	<ol style="list-style-type: none"> 1. Save the logbook to the SD card and then delete the logbook in the device 2. Set memory to ring memory 3. Deactivate logbook
531	Logbook full	M	On	Off	
532	License error	M	On	Off	--> Contact the Service Department
540	Parameter save	M	On	Off	Configuration saving has failed, --> repeat
541	Parameter load	M	On	Off	Configuration successfully loaded
542	Parameter load	M	On	Off	Configuration loading has failed, --> repeat
543	Parameter load	M	On	Off	Configuration loading aborted
544	Parameter reset	M	On	Off	Factory default successful
910	Limit switch	S	On	Off	Limit switch activated

No.	Message	Factory settings			Tests or remedial measures
		Cat.	Diag. on/off	Error current	
951 - 958	Hold active CH1 ... 8	C	On	Off	Output values and status of the channels are on hold. Wait until the hold is released again.
969	Modbus Watchdog	S	Off	Off	The device did not receive a Modbus telegram from the master within the specified time. The status of Modbus process values received is set to invalid.
970	Input Overload	S	On	On	Current input overloaded The current input is switched off from 23 mA due to overload and reactivated automatically when a normal load is present.
971	Input low	S	On	On	Current input too low At 4 to 20 mA, the input current is less than the lower error current --> Check the input for short-circuits.
972	Input > 20 mA	S	On	On	Current output range exceeded
973	Input < 4 mA	S	On	On	Current output range undershot
974	Diag. confirmed	C	Off	Off	User has acknowledged the message displayed in the measuring screen.
975	Device reset	C	Off	Off	Device reset
976	PFM value high	S	On	Off	Pulse frequency modulation: output signal exceeded/undershot. Measured value outside the specified range. Reasons: sensor in air, air pockets in assembly, incorrect flow to sensor, sensor fouled. 1. Clean the sensor 2. Check plausibility 3. Adjust the PFM configuration.
977	PFM value low	S	On	Off	
978	ChemoCl.Failsafe	S	On	On	No feedback signal detected within the configured period. 1. Check the application 2. Check the wiring 3. Extend the duration
990	Deviation limit	F	On	On	Redundancy: limit value of percentage deviation exceeded
991	CO2 conc. range	F	On	On	CO ₂ concentration (degassed conductivity) outside the measuring range
992	pH calc range	F	On	On	pH calculation outside the measuring range
993	rH calc range	F	On	On	rH calculation outside the measuring range
994	Dual cond range	F	On	On	Dual conductivity outside the measuring range

11.6.2 Sensor-specific diagnostics messages

See Operating Instructions for "Memosens", BA01245C

11.7 Pending diagnostic messages

The Diagnostics menu contains all the information on the device status. Furthermore, various service functions are available.

The following messages are directly displayed every time you enter the menu:

- "Most important message"
Diagnostics message recorded with the highest criticality level
- "Past message"
Diagnostic message whose cause is no longer present.

All the other functions in the Diagnostics menu are described in the following chapters.

11.8 Diagnostics list

All the current diagnostics messages are listed here.

A time stamp is available for each message. Furthermore, the system also displays the configuration and description of the message as saved in "Menu/Setup/General settings/Diagnostics/Device behavior".

11.9 Event logbook

11.9.1 Available logbooks

Types of logbooks

- Logbooks physically available (all apart from the overall logbook)
- Database view of all logbooks (=overall logbook)

Logbook	Visible in	Max. entries	Can be disabled ¹⁾	Logbook can be deleted	Entries can be deleted	Can be exported
Overall logbook	All events	1000	Yes	No	Yes	No
Calibration logbook	Calibration events	75	(Yes)	No	Yes	Yes
Operation logbook	Configuration events	250	(Yes)	No	Yes	Yes
Diagnostics logbook	Diagnostic events	250	(Yes)	No	Yes	Yes
Version logbook	All events	50	No	No	No	Yes
Hardware version logbook	All events	125	No	No	No	Yes
Data logbook for sensors (optional)	Data logbooks	150,000	Yes	Yes	Yes	Yes

Logbook	Visible in	Max. entries	Can be disabled ¹⁾	Logbook can be deleted	Entries can be deleted	Can be exported
Debugging logbook	Only accessible with the special activation code (Service)	1000	Yes	No	Yes	Yes

1) Data in brackets means this depends on the overall logbook

11.9.2 Logbooks menu

Diagnostics/Logbooks

Function	Options	Info
▶ All events		Chronological list of all the logbook entries, with information on the type of event.
▶ Show	Events are displayed	Select a particular event to display more detailed information.
▶ Go to date	User input <ul style="list-style-type: none"> ▪ Go to date ▪ Time 	Use this function to go directly to a specific time in the list. In this way, you avoid having to scroll through all the information. The complete list is always visible, however.
▶ Calibration events		Chronological list of the calibration events.
▶ Show	Events are displayed	Select a particular event to display more detailed information.
▶ Go to date	User input <ul style="list-style-type: none"> ▪ Go to date ▪ Time 	Use this function to go directly to a specific time in the list. In this way, you avoid having to scroll through all the information. The complete list is always visible, however.
▷ Delete all entries	Action	You can delete all the calibration logbook entries here.
▶ Configuration events		Chronological list of the configuration events.
▶ Show	Events are displayed	Select a particular event to display more detailed information.
▶ Go to date	User input <ul style="list-style-type: none"> ▪ Go to date ▪ Time 	Use this function to go directly to a specific time in the list. In this way, you avoid having to scroll through all the information. The complete list is always visible, however.
▷ Delete all entries	Action	You can use this to delete all the operation logbook entries.
▶ Diagnostic events		Chronological list of the diagnostics events.
▶ Show	Events are displayed	Select a particular event to display more detailed information.

Diagnostics/Logbooks

Function	Options	Info
▶ Go to date	User input <ul style="list-style-type: none"> ▪ Go to date ▪ Time 	Use this function to go directly to a specific time in the list. In this way, you avoid having to scroll through all the information. The complete list is always visible, however.
▷ Delete all entries	Action	You can use this to delete all the diagnostics logbook entries.

You can view your data logbook entries graphically on the display ("Show plot").

You can also adapt the display to suit your individual requirements:

- If you press the navigator button in the graphic display, you are given additional options such as the zoom function and x/y movement of the graph.
- Furthermore, you can also define a cursor. If you select this option, you can move along the graph with the navigator and view the logbook entry (data stamp/measured value) in text form for every point in the graph.
- Simultaneous display of two logbooks ("Select 2nd plot" and "Show plot"), →  67:
 - A small cross marks the currently selected graph for which the zoom can be changed or a cursor used, for example.
 - In the context menu (press the navigator button), you can select the other graph. You can then apply the zoom function, a movement or a cursor to this graph.
 - Using the context menu, you can also select both graphs simultaneously. This enables you, for example, to use the zoom function on both graphs simultaneously.

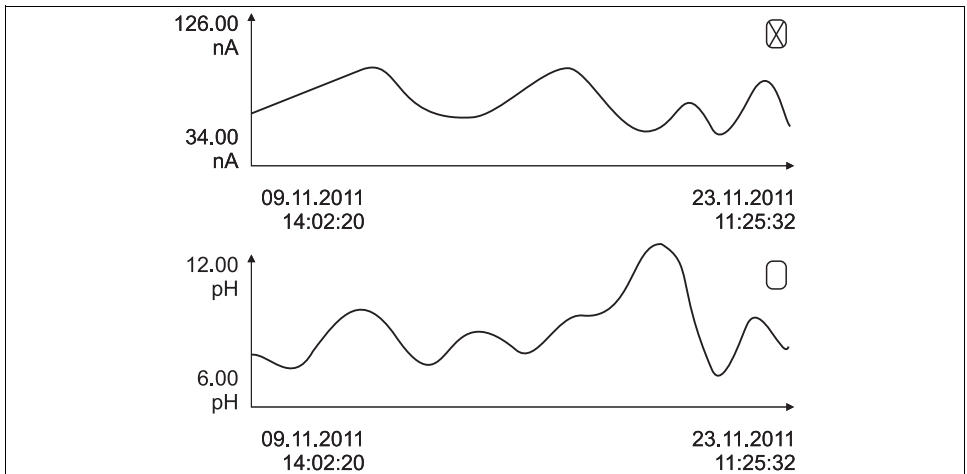

a0016688

Fig. 67: Simultaneous display of two graphs, the upper one is "selected"

Diagnostics/Logbooks

Function	Options	Info
▶ Data logbooks		Chronological list of the data logbook entries for sensors.
Data logbook 1 <Logbook name>		This submenu is available for each data logbook that you have set up and activated.
Source of data	Read only	Input or mathematical function is displayed
Measured value	Read only	Measured value being recorded is displayed
Log time left	Read only	Display of days, hours and minutes until logbook is full. Please note the instructions regarding the selection of the storage type in the General settings/Logbooks menu (-> BA "Operation and settings").
▶ Show	Events are displayed	Select a particular event to display more detailed information.
▶ Show plot	Graphic display of the logbook entries	The entries are displayed according to your settings in the General settings/Logbooks menu.
Select 2nd plot	Selecting another data logbook	You can view a second logbook at the same time as the current one.
▶ Go to date	User input <ul style="list-style-type: none"> ▪ Go to date ▪ Time 	Use this function to go directly to a specific time in the list. In this way, you avoid having to scroll through all the information. The complete list is always visible, however.
▷ Delete all entries	Action	You can use this to delete all data logbook entries.
▶ Save logbooks		
File format	Options <ul style="list-style-type: none"> ▪ CSV ▪ FDM 	Save the logbook in the preferred file format. You can then open the CSV file you saved on the PC in MS Excel, for example, and process it further ¹⁾ . You can import the FDM files into Fieldcare and archive them so they are tamper-proof.
▷ All data logbooks ▷ Data logbook 1 to n ▷ All event logbooks ▷ Calibration logbook ▷ Diagnostic logbook ▷ Configuration logbook ▷ HW version logbook ▷ Version logbook	The action commences as soon as the option is selected	Use this function to save the logbook to an SD card. <ul style="list-style-type: none"> ▶ Insert the SD card into the device card reader and select the logbook to be saved.
	The file name is made up of the "Logbook ident" (Menu/Setup/General settings/Logbooks), an abbreviation for the particular logbook and a time stamp.	

1) CSV files use international number formats and separators. Therefore they must be imported into MS Excel as external data with the correct format settings. If you double-click the file to open it, the data are only displayed correctly if MS Excel is installed with the US country setting.

11.10 Simulation

You can simulate values at inputs and outputs for testing purposes:

- Current values at current outputs
- Measured values at inputs

Diagnostics/Simulation

Function	Options	Info
▶ Current output:x:y		Simulation of an output current This menu appears once for each current output.
Simulation	Options <ul style="list-style-type: none"> ■ On ■ Off Factory setting Off	If you simulate the value at the current output, this is indicated on the display by a simulation icon in front of the current value.
Current	2.4 to 23.0 mA Factory setting 4 mA	Set the desired simulation value.
▶ Alarm relay ▶ Relay x:y		Simulation of a relay state This menu appears once for each relay.
Simulation	Options <ul style="list-style-type: none"> ■ On ■ Off Factory setting Off	If you simulate the relay state, this is indicated on the display by a simulation icon in front of the relay display.
State	Options <ul style="list-style-type: none"> ■ Low ■ High Factory setting Low	Set the desired state. The relay switches in accordance with your setting when you switch on the simulation. The display shows "On" (= "Low") or "Off" (= "High") for the simulated relay state.
▶ Meas. inputs		Simulation of a measured value This menu appears once for each measuring input.
▶ Channel : parameter		
Sim. main value	Options <ul style="list-style-type: none"> ■ On ■ Off Factory setting Off	If you simulate the measured value, this is indicated on the display by a simulation icon in front of the measured value.
Main value	Depends on the sensor Factory setting Depends on the sensor	Set the desired simulation value.
Sim. temperature	Options <ul style="list-style-type: none"> ■ On ■ Off Factory setting Off	If you simulate the temperature measured value, this is indicated on the display by a simulation icon in front of the temperature.

Diagnostics/Simulation

Function	Options	Info
Temperature	-50.0 to +250.0 °C (-58.0 to 482.0 °F) Factory setting 20.0 °C (68.0 °F)	Set the desired simulation value.

11.11 Reset measuring instrument**Diagnostics/Systemtest/Reset**

Function	Options	Info
▷ Device reset	Options <ul style="list-style-type: none"> ▪ OK ▪ ESC 	Restart and keep all the settings
▷ Factory default	Options <ul style="list-style-type: none"> ▪ OK ▪ ESC 	Restart with factory settings Settings that have not been saved are lost.
▶ Power supply	Read only <ul style="list-style-type: none"> ▪ Digital Supply 1: 1.2V ▪ Digital Supply 2: 3.3V ▪ Analog Supply: 12.5V ▪ Sensor Supply: 24V ▪ Temperature 	Detailed list of power supply to instrument.  The actual values can vary without a malfunction being present.

11.12 Device information

11.12.1 System information

Diagnostics/System information

Function	Options	Info
Device tag	Read only	Individual device tag, --> "General settings"
Order code	Read only	You can order identical hardware with this code. This code changes on account of changes to the hardware and you can enter the new code you received from the manufacturer here ¹⁾ .
 To find out what device version you have, enter the order code in the search screen at the following address: www.products.endress.com/order-ident		
Orig. order code ext.	Read only	Complete order code for the original device, resulting from the product structure.
Current order code ext.	Free text	Current code, taking into account changes to the hardware. You must enter this yourself.
Serial number	Read only	The serial number allows you to access device data and documentation on the Internet: www.products.endress.com/device-viewer
Software version	Read only	Current version
▶ HART <i>only with HART option</i>	Read only <ul style="list-style-type: none"> ▪ Bus address ▪ Unique address ▪ Manufacturer ID ▪ Device type ▪ Device revision ▪ Software revision 	HART-specific information The unique address is linked to the serial number and is used to reach devices in a multi-drop environment. Device and software version numbers are incremented as soon as changes have been made.
▶ Modbus <i>only with Modbus TCP or Modbus RS485 option</i>	Read only <ul style="list-style-type: none"> ▪ Enable ▪ Bus address ▪ Termination ▪ Modbus TCP Port 502 	Modbus-specific information
▶ PROFIBUS DP <i>only with PROFIBUS DP option</i>	Read only <ul style="list-style-type: none"> ▪ DPVO state 	Module status
▶ Ethernet <i>only with Ethernet, Modbus TCP, Modbus RS485 or PROFIBUS DP option</i>	Read only <ul style="list-style-type: none"> ▪ Enable ▪ Webserver ▪ IP-Address ▪ Netmask ▪ Gateway ▪ MAC-Address ▪ Modbus TCP Port 502 ▪ Webserver TCP Port 80 	Ethernet-specific information
▶ SD card	Read only <ul style="list-style-type: none"> ▪ Total ▪ Free memory 	Total memory and space available

Diagnostics/System information

Function	Options	Info
▶ System modules		
Depends on the electronics module available, e.g.: Base	Read only <ul style="list-style-type: none"> ■ Description ■ Serial number ■ Order code ■ Hardware version ■ Software version 	This information is provided for every electronics module available. Specify the serial numbers and order codes when servicing, for example.
▶ Sensors		
Depends on the sensors connected	Read only <ul style="list-style-type: none"> ■ Description ■ Serial number ■ Order code ■ Hardware version ■ Software version 	This information is provided for every sensor available. Specify the serial numbers and order codes when servicing, for example.

1) Provided you give the manufacturer all the information about changes to the hardware.

11.12.2 Sensor information

Select the channel you want from the list of channels.

Information in the following categories is displayed:

- Extreme values
Extreme conditions to which the sensor was previously exposed, e.g. min./max. temperatures²⁾
- Operating time
Operating time of the sensor under defined extreme conditions
- Calibration information
Calibration data of the last calibration
- Sensor specifications
Measuring range limits for main measured value and temperature
- General information
Sensor identification information

The specific data that are displayed depends on what sensor is connected.

2) Not available for all sensor types.

11.13 Firmware history

Date	Version	Changes to software	Documentation: edition
12/2013	01.05.00	Extension <ul style="list-style-type: none"> ■ Chemoclean Plus ■ Calendar function for cleaning ■ Conductivity: <ul style="list-style-type: none"> – Measuring range switching also for conductive conductivity measurement – External temperature signal via current input ■ Oxygen: <ul style="list-style-type: none"> – External pressure or temperature signals via current input – Connected conductivity sensor can be used to calculate the salinity. ■ SAC, nitrate, turbidity: <ul style="list-style-type: none"> – Calibration settings can be configured via fieldbus ■ Channel-specific diagnostics codes for HOLD function. Improvement <ul style="list-style-type: none"> ■ Web server login for managing multiple users ■ Set point and PID parameters for controllers can be configured via fieldbus 	BA01225C/07/EN/02.13 BA00486C/07/EN/02.13 BA01245C/07/EN/01.13
07/2013	01.04.00	Original firmware	BA01225C/07/EN/01.13 BA01227C/07/EN/01.13 BA00450C/07/EN/17.13 BA00451C/07/EN/16.13 BA00486C/07/EN/02.13

12 Maintenance

⚠ WARNING

Process pressure and temperature, contamination, electrical voltage

Risk of serious or fatal injury

- ▶ If the sensor has to be removed during maintenance work, avoid hazards posed by pressure, temperature and contamination.
- ▶ De-energize the device before opening it.
- ▶ Power can be supplied to switching contacts from separate circuits. De-energize these circuits before working on the terminals.

NOTICE

Electrostatic discharge (ESD)

Risk of damage to electronic components

- ▶ Take personal protective measures to avoid ESD, such as discharging beforehand at PE or permanent grounding with a wrist strap.
- ▶ For your own safety, use only genuine spare parts. With genuine parts, the function, accuracy and reliability are also ensured after maintenance work.

12.1 Calibration

Sensors with Memosens protocol are calibrated at the factory.

Users must decide whether the process conditions present require calibration during initial commissioning.

Additional calibration is not required in many standard applications.

Calibrate the sensors at sensible intervals depending on the process.

 All information on calibration is provided in BA01245C "Memosens".

12.2 Cleaning

12.2.1 External display (in installed state)

Only clean the front of the housing with commercially available cleaning agents.

The front is resistant to the following as per DIN 42 115:

- Ethanol (short periods)
- Diluted acids (max. 2% HCl)
- Diluted bases (max. 3% NaOH)
- Soap-based household cleaners

NOTICE

Prohibited cleaning agents

Damage to the housing surface or housing seal

- ▶ For cleaning purposes, never use concentrated mineral acids or bases.
- ▶ Never use organic cleaners such as benzyl alcohol, methanol, methylene chloride, xylene or concentrated glycerol cleaner.
- ▶ Never use high-pressure steam for cleaning purposes.

12.2.2 Digital sensors

⚠ CAUTION

The cleaning system is not switched off during calibration or maintenance activities

Risk of injury due to medium or cleaning agent

- ▶ If a cleaning system is connected, switch it off before removing a sensor from the medium.
 - ▶ If you are not switching off the cleaning system because you wish to test the cleaning function, wear protective clothing, goggles and gloves or take other appropriate measures.
1. If an error occurs or the maintenance schedule stipulates that the sensor has to be replaced, use a new sensor or a sensor that has been precalibrated in the laboratory. A sensor is calibrated in the laboratory under optimum external conditions, thereby ensuring better quality of measurement.
 2. Remove the sensor to be serviced and install the new sensor.
 3. You must perform calibration if you use a sensor that is not precalibrated.
 4. The sensor data are automatically accepted by the transmitter. A release code is not required.
 5. Measurement is resumed.
 6. Take the used sensor back to the laboratory. In the laboratory you can get the sensor ready for reuse while ensuring the availability of the measuring point.
 - Clean the sensor. For this purpose, use the cleaning agent specified in the sensor manual.
 - Inspect the sensor for cracks or other damage.
 - If no damage is found, regenerate the sensor. Where necessary, store the sensor in a regeneration solution (--> sensor manual).
 - Recalibrate the sensor for reuse.

12.2.3 Assemblies

Refer to the assembly operating manual for information on servicing and troubleshooting the assembly. The assembly operating manual describes the procedure for mounting and disassembling the assembly, replacing the sensors and seals, and contains information on the material resistance properties, as well as spare parts and accessories.

13 Repair

13.1 Spare parts

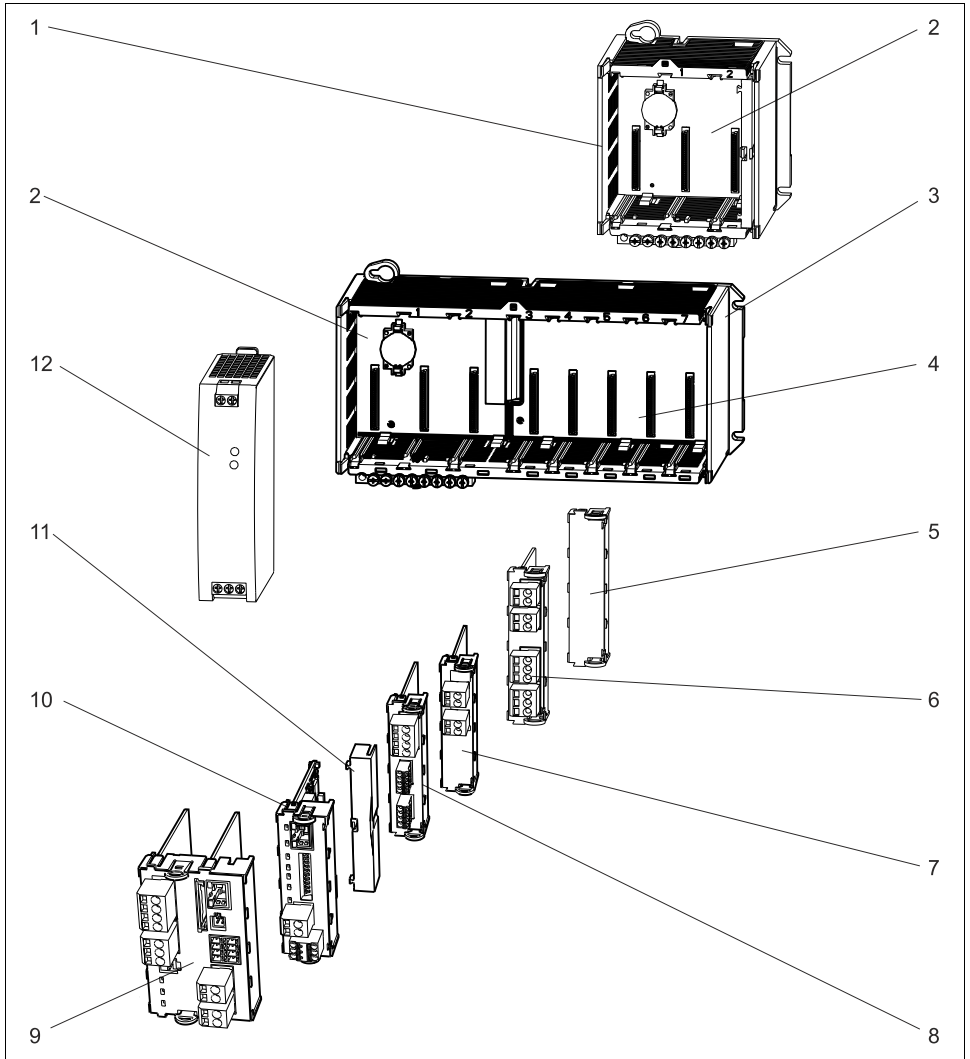

Fig. 68: Spare parts: You can find the names of spare parts and their order numbers in the following table.

a0020679

NOTICE**Damaged cables from careless maintenance or repair work**

- ▶ Exercise care when replacing defective cables, particularly if you are removing them from a cable duct.
- ▶ Preferably use a junction box, which then acts as a stationary connection into the cabinet.

Item	Kit CM44x	Order number
1	Kit CM442R <ul style="list-style-type: none"> ▪ Control cabinet installation housing, complete 	71222273
2	Kit CM44x/CM44xR: electronics module backplane <ul style="list-style-type: none"> ▪ Backplane complete ▪ To be replaced only by Endress+Hauser Service 	71101457
3	Kit CM444R/448R <ul style="list-style-type: none"> ▪ Control cabinet installation housing, complete 	71222276
4	Kit CM44x/CM44xR: electronics module extension backplane <ul style="list-style-type: none"> ▪ Extension backplane complete ▪ To be replaced only by Endress+Hauser Service 	71141366
5, 11	Kit CM44xR <ul style="list-style-type: none"> ▪ Set of covers for shock protection 	71222282
9	Kit CM442: base module BASE-L 24V AC/DC <ul style="list-style-type: none"> ▪ Base module 24V AC/DC complete ▪ End cover (item 8) ▪ Instructions for spare parts kit CM44x 	71100607
	Kit CM442: base module BASE-H 230V AC <ul style="list-style-type: none"> ▪ Base module 230V AC, complete ▪ End cover (item 8) ▪ Instructions for spare parts kit CM44x 	71100611
	Kit CM444/CM448: base module BASE-E <ul style="list-style-type: none"> ▪ Base module, complete ▪ End cover (item 8) ▪ Connecting cable to connect to the power unit ▪ Instructions for spare parts kit CM44x 	71141336
	Kit CM44x: terminal set, base module	71107452

Item	Kit CM44x	Order number
6, 7, 8, 10	Kit CM44x/ CM44xR: extension module AOR (2 relays + 2 current outputs) <ul style="list-style-type: none"> ▪ Extension module AOR, complete ▪ Instructions for spare parts kit CM44x 	71111053
	Kit CM44x/CM44xR: terminal set, extension module AOR	71107453
	Kit CM44x/CM44xR: extension module 2R (2 relays) <ul style="list-style-type: none"> ▪ Extension module 2R complete ▪ Instructions for spare parts kit CM44x 	71125375
	Kit CM44x/CM44xR: extension module 4R (4 relays) <ul style="list-style-type: none"> ▪ Extension module 4R complete ▪ Instructions for spare parts kit CM44x 	71125376
	Kit CM44x/CM44xR: terminal set, extension module 2R, 4R	71155581
	Kit CM44x/CM44xR: extension module 2AO (2 x 0/4 to 20 mA) <ul style="list-style-type: none"> ▪ Extension module 2AO complete ▪ Instructions for spare parts kit CM44x 	71135632
	Kit CM44x/CM44xR: extension module 4AO (4 x 0/4 to 20 mA) <ul style="list-style-type: none"> ▪ Extension module 4AO complete ▪ Instructions for spare parts kit CM44x 	71135633
	Kit CM44x/CM44xR: terminal set, extension module 2AO, 4AO	71155582
	Kit CM44x/CM44xR: extension module DIO (2 x digital input, digital output in each case) <ul style="list-style-type: none"> ▪ Extension module DIO, complete ▪ Instructions for CM44x/CM44xR spare parts kits 	71135638
	Kit CM44x/CM44xR: terminal set, extension module DIO	71219784
	Kit CM44x/CM44xR: extension module 2DS (2 x digital sensor) <ul style="list-style-type: none"> ▪ Extension module 2DS complete ▪ Instructions for spare parts kit CM44x 	71135631
	Kit CM44x/CM44xR: extension module 2AI (2 x analog input 0/4 to 20 mA) <ul style="list-style-type: none"> ▪ Extension module 2AI complete ▪ Instructions for spare parts kit CM44x 	71135639
	Kit CM44x/CM44xR: extension module 485 (Ethernet configuration) <ul style="list-style-type: none"> ▪ Extension module 485 complete ▪ With activation code extendable to PROFIBUS DP or Modbus RS 485 or Modbus TCP or EtherNet/IP ▪ Instructions for spare parts kit CM44x 	71135634
	Kit CM44x/CM44xR: terminal set for extension module 2AI, 485	71155583
12	Kit CM444R/BR: DIN rail power unit <ul style="list-style-type: none"> ▪ DIN rail power unit 110 to 230 VAC ▪ DIN rail power unit 24 VDC 	<ul style="list-style-type: none"> ▪ 71222277 ▪ 71222279

13.2 Return

The product has to be returned in the event of repair, factory calibration, incorrect delivery or incorrect ordering. As an ISO-certified company and due to legal regulations, Endress+Hauser is obligated to use particular handling techniques for all returned products that have come into contact with a medium.

In order to ensure a reliable, proper and quick return:

Learn about the methods and basic conditions at the Internet site

www.services.endress.com/return-material

13.3 Disposal

The device contains electronic components and must therefore be disposed of in accordance with regulations on the disposal of electronic waste.

Please observe local regulations.



The battery located on the backplane must be disposed of in accordance with local regulations governing the disposal of batteries.

14 Accessories



The most important accessories available at the time this document went to print are listed below. Contact your service representative or Sales Center for accessories that are not listed here.

14.1 Measuring cable

Memosens data cable CYK10

- For digital sensors with Memosens technology
pH, redox, oxygen (amperometric), chlorine, conductivity (conductive)
- Order as per product structure (--> Online Configurator, www.products.endress.com/cyk10)
- Technical Information TIO0118C/07/EN

Memosens data cable CYK11

- Extension cable for digital sensors with Memosens protocol
- Order as per product structure (--> Online Configurator, www.products.endress.com/cyk11)

Measuring cable CYK81

- Unterminated cable for extending sensor cables (e.g. Memosens)
- 2 x 2 cores, twisted with shielding and PVC sheath (2 x 2 x 0.5 mm² + shielding)
- Material sold by the meter, Order No.: 51502543

14.2 Sensors

14.2.1 Glass electrodes

Orbisint CPS11D

- pH sensor with Memosens technology
- Dirt-resistant PTFE diaphragm
- Order as per product structure (--> Online Configurator, www.products.endress.com/cps11d)
- Technical Information TI00028C/07/EN

Memosens CPS31D

- pH sensor with Memosens technology
- Gel-filled reference system with ceramic diaphragm
- Order as per product structure (--> Online Configurator, www.products.endress.com/cps31d)
- Technical Information TI00030C/07/EN

Ceraliquid CPS41D

- pH sensor with Memosens technology
- Ceramic diaphragm and KCl liquid electrolyte
- Order as per product structure (--> Online Configurator, www.products.endress.com/cps41d)
- Technical Information TI00079C/07/EN

Ceragel CPS71D

- pH sensor with Memosens technology
- Poison-resistant reference with ion trap
- Order as per product structure (--> Online Configurator, www.products.endress.com/cps71d)
- Technical Information TI00245C/07/EN

Orbipore CPS91D

- pH sensor with Memosens technology
- Open aperture junction for media with high potential for fouling
- Order as per product structure (--> Online Configurator, www.products.endress.com/cps91d)
- Technical Information TI00375C/07/EN

Orbipac CPF81D

- pH compact sensor for installation or immersion operation in industrial water and wastewater
- Order as per product structure (--> Online Configurator, www.products.endress.com/cpf81d)
- Technical Information TI191C/07/EN

14.2.2 Enamel pH electrodes

Ceramax CPS341D

- pH electrode with pH-sensitive enamel
- For the toughest requirements in terms of precision, pressure, temperature, sterility and operating life
- Order as per product structure (--> Online Configurator, www.products.endress.com/cps341d)
- Technical Information TI00468C/07/EN

14.2.3 ORP sensors

Orbisint CPS12D

- ORP sensor with Memosens technology
- Dirt-resistant PTFE diaphragm;
- Order as per product structure (--> Online Configurator, www.products.endress.com/cps12d)
- Technical Information TI367C/07/EN

Ceraliquid CPS42D

- ORP sensor with Memosens technology
- Ceramic diaphragm and KCl liquid electrolyte
- Order as per product structure (--> Online Configurator, www.products.endress.com/cps42d)
- Technical Information TI373C/07/EN

Ceragel CPS72D

- ORP sensor with Memosens technology
- Poison-resistant reference with ion trap
- Order as per product structure (--> Online Configurator, www.products.endress.com/cps72d)
- Technical Information TI374C/07/EN

Orbipac CPF82D

- Redox compact sensor for installation or immersion operation in industrial water and wastewater
- Order as per product structure (--> Online Configurator, www.products.endress.com/cpf82d)
- Technical Information TI191C/07/EN

Orbipore CPS92D

- ORP sensor with Memosens technology
- Open aperture junction for media with high potential for fouling
- Order as per product structure (--> Online Configurator, www.products.endress.com/cps92d)
- Technical Information TI435C/07/EN

14.2.4 pH-ISFET sensors

Tophit CPS471D

- Sterilizable and autoclavable ISFET sensor with Memosens technology
- For food and pharmaceutical industry, process engineering, water treatment and biotechnology
- Order as per product structure (--> Online Configurator, www.products.endress.com/cps471d)
- Technical Information TI283C/07/EN

Tophit CPS441D

- Sterilizable ISFET sensor with Memosens technology
- For low-conductivity media, with liquid KCl electrolyte
- Order as per product structure (--> Online Configurator, www.products.endress.com/cps441d)
- Technical Information TI352C/07/EN

Tophit CPS491D

- ISFET sensor with Memosens technology
- Open aperture diaphragm for media with high potential for fouling
- Order as per product structure (--> Online Configurator, www.products.endress.com/cps491d)
- Technical Information TI377C/07/EN

14.2.5 pH/ORP combined sensors

Memosens CPS16D

- Combined pH/ORP sensor for process technology, with dirt-repellent PTFE diaphragm
- With Memosens technology
- Order as per product structure (--> Online Configurator, www.products.endress.com/cps16d)
- Technical Information TI00503C/07/EN

Memosens CPS76D

- Combined pH/ORP sensor for process technology, hygiene and sterile applications
- With Memosens technology
- Order as per product structure (--> Online Configurator, www.products.endress.com/cps76d)
- Technical Information TI00506C/07/EN

Memosens CPS96D

- Combined pH/ORP sensor for chemical processes
- With poison-resistant reference with ion trap
- With Memosens technology
- Order as per product structure (--> Online Configurator, www.products.endress.com/cps96d)
- Technical Information TI00507C/07/EN

14.2.6 Inductive conductivity sensors

Indumax CLS50D

- Inductive conductivity sensor with very good resistance properties for standard, Ex and high-temperature applications
- Memosens protocol
- Order as per product structure (--> Online Configurator, www.products.endress.com/cls50d)
- Technical Information TI182C/07/EN

Indumax H CLS54D

- Inductive conductivity sensor with certified, hygienic design for foodstuffs, beverages, the pharmaceutical industry and biotechnology
- Order as per product structure, (--> Online Configurator, www.products.endress.com/cls54d)
- Technical Information TI00508C/07/EN

14.2.7 Conductive conductivity sensors

Condumax CLS15D

- Conductive conductivity sensor for pure water, ultrapure water and Ex applications
- Order as per product structure (--> Online Configurator, www.products.endress.com/cls15d)
- Technical Information TI00109C/07/EN

Condumax CLS16D

- Hygienic, conductive conductivity sensor for pure water, ultrapure water and EX applications
- With EHEDG and 3A approval
- Order as per product structure (--> Online Configurator, www.products.endress.com/cls16d)
- Technical Information TI227C/07/EN

Condumax CLS21D

- Two-electrode sensor in plug-in head and fixed cable version
- Order as per product structure (--> Online Configurator, www.products.endress.com/cls21d)
- Technical Information TI085C/07/EN

14.2.8 Oxygen sensors

Oxymax COS51D

- Amperometric sensor for dissolved oxygen, with Memosens technology
- Order as per product structure (--> Online Configurator, www.products.endress.com/cos51d)
- Technical Information TI00413C/07/EN

Oxymax COS61D

- Optical oxygen sensor for drinking water and industrial water measurement
- Measuring principle: quenching
- Memosens protocol
- Material: stainless steel 1.4571 (AISI 316Ti)
- Order as per product structure (--> Online Configurator, www.products.endress.com/cos61d)
- Technical Information TI387C/07/EN

Oxymax COS22D

- Sterilizable sensor for dissolved oxygen
- Order as per product structure (--> Online Configurator, www.products.endress.com/cos22d)
- Technical Information TI446C/07/EN

14.2.9 Chlorine sensors

CCS142D

- Membrane-covered amperometric sensor for free chlorine
- Memosens technology
- Measuring range 0.01 to 20 mg/l
- Order as per product structure (--> Online Configurator, www.products.endress.com/ccs142d)
- Technical Information TI419C/07/EN

14.2.10 Ion-selective sensors

ISEmax CAS40D

- Ion-selective sensors
- Order as per product structure (--> Online Configurator, www.products.endress.com/cas40d)
- Technical Information TI491C/07/EN

14.2.11 Turbidity sensors

Turbimax CUS51D

- For nephelometric turbidity and solids measurement in wastewater
- 4-beam alternating light method based on scattered light
- With Memosens protocol
- Order as per product structure (--> Online Configurator, www.products.endress.com/cus51d)
- Technical Information TI461C/07/EN

14.2.12 SAC and nitrate sensors

Viomax CAS51D

- SAC and nitrate measurement in drinking water and wastewater
- With Memosens protocol
- Order as per product structure (--> Online Configurator, www.products.endress.com/cas51d)
- Technical Information TI459C/07/EN

14.2.13 Interface measurement

Turbimax CUS71D

- Immersion sensor for interface measurement
- Ultrasonic interface sensor
- Order as per product structure (--> Online Configurator, www.products.endress.com/cus71d)
- Technical Information TI490C/07/EN

14.3 Additional functionality

14.3.1 Hardware extension modules

Kit CM442/CM444/CM448/CM442R/CM444R/CM448R/CSF48: extension module AOR

- 2 x relay, 2 x analog output 0/4 to 20 mA
- Order No. 71111053

Kit CM442/CM444/CM448/CM442R/CM444R/CM448R/CSF48: extension module 2R

- 2 x relay
- Order No. 71125375

Kit CM442/CM444/CM448/CM442R/CM444R/CM448R/CSF48: extension module 4R

- 4 x relay
- Order No. 71125376

Kit CM442/CM444/CM448/CM442R/CM444R/CM448R/CSF48: extension module 2AO

- 2 x analog output 0/4 to 20 mA
- Order No. 71135632

Kit CM444/CM448/CM444R/CM448R/CSF48: extension module 4AO

- 4 x analog output 0/4 to 20 mA
- Order No. 71135633

Kit CM444/CM448/CM444R/CM448R/CSF48: extension module 2DS

- 2 x digital sensor, Memosens
- Order No. 71135631

Kit CM442/CM444/CM448/CM442R/CM444R/CM448R/CSF48: extension module 2AI

- 2 x analog input 0/4 to 20 mA
- Order No. 71135639

Kit CM442/CM444/CM448/CM442R/CM444R/CM448R/CSF48: extension module DIO

- 2 x digital input
- 2 x digital output
- Auxiliary voltage supply for digital output
- Order no. 71135638

Kit CM442/CM444/CM448/CM442R/CM444R/CM448R/CSF48: extension module 485

- Ethernet configuration
- Can be extended to PROFIBUS DP or Modbus RS485 or Modbus TCP or EtherNet/IP. This requires an additional activation code which can be ordered separately (→  144).
- Order No. 71135634

Upgrade kit CM442/CM444/CM448/CM442R/CM444R/CM448R/CSF48

- Extension module 485
- PROFIBUS DP (+ Ethernet configuration)
- Order No. 71140888

Upgrade kit CM442/CM444/CM448/CM442R/CM444R/CM448R/CSF48

- Extension module 485
- Modbus RS485 (+ Ethernet configuration)
- Order No. 71140889

Upgrade kit CM442/CM444/CM448/CM442R/CM444R/CM448R/CSF48

- Extension module 485
- Modbus TCP (+ Ethernet configuration)
- Order No. 71140890

Upgrade kit CM442/CM444/CM448/CM442R/CM444R/CM448R/CSF48

- Extension module 485
- EtherNet/IP (+ Ethernet configuration)
- Order No. 71219868

14.3.2 Firmware and activation codes

SD card with Liquiline firmware

- Industrial Flash Drive, 1 GB
- Order No. 71127100

Activation code for digital HART communication

- Order No. 71128428

Activation code for PROFIBUS DP

- Order No. 71135635

Activation code for Modbus RS485

- Order No. 71135636

Activation code for Modbus TCP

- Order No. 71135637

Activation code for EtherNet/IP

- Order No. 71219871

Kit CM442R: Activation code for 2nd digital sensor input

- Order No. 71114663

Kit CM444R/CM448R: Upgrade code for 2 x 0/4 to 20 mA for BASE-E

- Order No. 71140891

Activation code for feedforward control

- Order no. 71211288

Activation code for measuring range switch

- Order no. 71211289

14.4 Software

Memobase Plus CYP71D

- PC software for supporting laboratory calibration
- Visualization and documentation of sensor management
- Database storage of sensor calibrations
- Order as per product structure, www.products.endress.com/cyp71d
- Technical Information TI00502C/07/EN

MS30 Field Data Manager software

- PC software for centralized data management
- Visualization of measurement series and logbook events
- SQL database for secure storage
- Order No. 71129799

14.5 Other accessories

14.5.1 External display

Graphic display

- For installation in the cabinet door or panel
- Order No. 71185295

Service display

- Portable, for commissioning
- Order No. 71185296

14.5.2 SD card

SD card

- Industrial Flash Drive, 1 GB
- Order No. 71110815

14.5.3 Communication-specific accessories

Commubox FXA195 HART

- Intrinsically safe HART communication with FieldCare via the USB port
- Technical Information TI00404F

Commubox FXA291

- Connects the CDI interface of measuring devices with the USB port of the computer or laptop
- Technical Information TI00405C

WirelessHART adapter SWA70

- Wireless device connection
- Easily integrated, offers data protection and transmission safety, can be operated in parallel with other wireless networks, minimum cabling complexity
- Technical Information TI00061S

Fieldgate FXA320

- Gateway for the remote interrogation of 4-20 mA measuring devices via a Web browser
- Technical Information TI00025S

Fieldgate FXA520

- Gateway for the remote diagnostics and configuration of connected HART devices via a Web browser
- Technical Information TI00051S

Field Xpert SFX100

- Compact, flexible and robust industrial handheld terminal for remote configuration and for obtaining measured values via the HART current output
- Operating Instructions BA00060S

14.5.4 System components

RIA14, RIA16

- Field display unit for integration into 4-20 mA circuits
- RIA14 in flameproof metal enclosure
- Technical Information TI00143R and TI00144R

RIA15

- Process display unit, Digital display unit for integration into 4-20 mA circuits
- Panel mounting
- With optional HART communication
- Technical Information TI01043K

15 Technical data

15.1 Input

15.1.1 Measured variables

--> Documentation of the connected sensor

15.1.2 Measuring ranges

--> Documentation of the connected sensor

15.1.3 Input types

- digital sensor inputs for sensors with Memosens protocol
- Analog current inputs (optional)
- Digital inputs (optional)

15.1.4 Input signal

Depending on version

- Max. 8 x binary sensor signal
- 2 x 0/4 to 20 mA (optional), passive, potentially isolated from the sensor inputs and from one another
- 0 to 30 V

15.1.5 Cable specification

Cable type

Memosens data cable CYK10 or fixed sensor cable, each with cable end sleeves or M12 round-pin connector

Cable length

Max. 100 m (330 ft)

15.2 Digital inputs, passive

15.2.1 Electrical specification

- drawing power (passive)
- galvanically isolated

15.2.2 Span

High: 11 to 30 V DC

Low: 0 to 5 V DC

15.2.3 Nominal input current

Max. 8 mA

15.2.4 PFM function

Minimum pulse width: 500 μ s (1 kHz)

15.2.5 Testing voltage

500 V

15.2.6 Cable specification

Max. 2.5 mm² (14 AWG)

15.3 Current input, passive

15.3.1 Span

> 0 to 20 mA

15.3.2 Signal characteristic

Linear

15.3.3 Internal resistance

Non-linear

15.3.4 Testing voltage

500 V

15.4 Output

15.4.1 Output signal

Depending on version:

- 2 x 0/4 to 20 mA, active, potentially isolated from one another and from the sensor circuits
- 4 x 0/4 to 20 mA, active, potentially isolated from one another and from the sensor circuits
- 6 x 0/4 to 20 mA, active, potentially isolated from one another and from the sensor circuits
- 8 x 0/4 to 20 mA, active, potentially isolated from one another and from the sensor circuits
- Optional HART communication (only via current output 1:1)

HART

Signal encoding	FSK \pm 0.5 mA via current signal
Data transmission rate	1200 Baud
Galvanic isolation	Yes
Load (communication resistor)	250 Ω

PROFIBUS DP

Signal encoding	EIA/TIA-485, PROFIBUS-DP-compliant as per IEC 61158
Data transmission rate	9.6 kBd, 19.2 kBd, 45.45kBd, 93.75 kBd, 187.5 kBd, 500 kBd, 1.5 MBd, 6 MBd, 12 MBd
Galvanic isolation	Yes
Bus termination	Internal slide switch with LED display

Modbus RS485

Signal encoding	EIA/TIA-485
Data transmission rate	2400, 4800, 9600, 19200, 38400, 57600 and 115200 Baud
Galvanic isolation	Yes
Bus termination	Internal slide switch with LED display

Ethernet and Modbus TCP

Signal encoding	IEEE 802.3 (ethernet)
Data transmission rate	10 / 100 MBd
Galvanic isolation	Yes
IP address	DHCP or configuration via menu

EtherNet/IP

Signal encoding	IEEE 802.3 (ethernet)
Data transmission rate	10 / 100 MBd
Galvanic isolation	Yes
Connection	RJ45
IP address	DHCP (default) or configuration via menu

15.4.2 Signal on alarm

Adjustable, as per NAMUR Recommendation NE 43

- In measuring range 0 to 20 mA (HART is not available with this measuring range):
 - Error current from 0 to 23 mA
- In measuring range 4 to 20 mA:
 - Error current from 2.4 to 23 mA
- Error current factory setting for both measuring ranges:
 - 21.5 mA

15.4.3 Load

Max. 500 Ω

15.4.4 Linearization/transmission behavior

Linear

15.5 Digital outputs, passive

15.5.1 Electrical specification

- Passive
- Open collector, max. 30 V, 15 mA

15.5.2 PFM function

Minimum pulse width: 500 μ s (1 kHz)

15.5.3 Auxiliary voltage

Electrical specification

- Galvanically isolated
- Unregulated, 24 V DC \pm 20%
- Max. 50 mA

15.5.4 Testing voltage

500 V

15.5.5 Cable specification

Max. 2.5 mm² (14 AWG)

15.6 Current output, active

15.6.1 Span

0 to 23 mA

2.4 to 23 mA for HART communication

15.6.2 Signal characteristic

Linear

15.6.3 Electrical specification

Output voltage

Max. 24 V

Testing voltage

500 V

15.6.4 Cable specification

Cable type

Recommended: shielded cable

Cross-section

Max. 2.5 mm² (14 AWG)

15.7 Relay outputs

15.7.1 Relay types

- 1 single-pin changeover contact (alarm relay)
- 2 or 4 single-pin changeover contacts (optional with extension modules)

15.7.2 Relay switching capacity

Base module (alarm relay)

Switching voltage	Load (max.)	Switching cycles (min.)
230 V AC, $\cos\phi = 0.8$ to 1	0.1 A	700,000
	0.5 A	450,000
115 V AC, $\cos\phi = 0.8$ to 1	0.1 A	1,000,000
	0.5 A	650,000
24 V DC, L/R = 0 to 1 ms	0.1 A	500,000
	0.5 A	350,000

Extension modules

Switching voltage	Load (max.)	Switching cycles (min.)
230 V AC, $\cos\phi = 0.8$ to 1	0.1 A	700,000
	0.5 A	450,000
	2 A	120,000
115 V AC, $\cos\phi = 0.8$ to 1	0.1 A	1,000,000
	0.5 A	650,000
	2 A	170,000
24 V DC, L/R = 0 to 1 ms	0.1 A	500,000
	0.5 A	350,000
	2 A	150,000

Minimum load (typical)

- Min. 100 mA for 5 V DC
- Min. 1 mA for 24 V DC
- Min. 5 mA for 24 V AC
- Min. 1 mA for 230 V AC

15.7.3 Cable cross-section

Max. 2.5 mm² (14 AWG)

15.8 Protocol-specific data

15.8.1 HART

Manufacturer ID	11 _h
Device type	119C _h (CM44x), 119D _h (CSFxx)
Device revision	001 _h
HART version	7.2
Device description files (DD/DTM)	www.endress.com Device Integration Manager (DIM)
Device variables	16 user-definable and 16 predefined device variables, dynamic variables PV, SV, TV, QV
Supported features	PDM DD, AMS DD, DTM, Field Xpert DD

15.8.2 PROFIBUS DP

Manufacturer ID	11 _h
Device type	155D _h (CM44x)
Profile version	3.02
Device master files (GSD)	www.products.endress.com/profibus Device Integration Manager DIM
Output	16 AI blocks, 8 DI blocks
Input	4 AO blocks, 8 DO blocks
Supported features	<ul style="list-style-type: none"> ▪ 1 MSCY0 connection (cyclic communication, master Class 1 to slave) ▪ 1 MSAC1 connection (acyclic communication, master Class 1 to slave) ▪ 2 MSAC2 connections (acyclic communication, master Class 2 to slave) ▪ Device lock: the device can be locked via the hardware or software. ▪ Addressing using DIL switches or via the software ▪ GSD, PDM DD, DTM

15.8.3 Modbus RS485

Protocol	RTU / ASCII
Function codes	03, 04, 06, 08, 16, 23
Broadcast support for function codes	06, 16, 23
Output data	16 measured values (value, unit, status), 8 digital values (value, status)
Input data	4 setpoint values (value, unit, status), 8 digital values (value, status), diagnostics information
Supported features	Address can be configured via switches or the software

15.8.4 Modbus TCP

TCP port	502
TCP connections	3
Protocol	TCP
Function codes	03, 04, 06, 08, 16, 23
Broadcast support for function codes	06, 16, 23
Output data	16 measured values (value, unit, status), 8 digital values (value, status)
Input data	4 setpoint values (value, unit, status), 8 digital values (value, status), diagnostics information
Supported features	Address can be configured via DHCP or the software

15.8.5 EtherNet/IP

Protocol	EtherNet/IP	
ODVA certification	Yes	
Device profile	Generic device (product type: 0x2B)	
Manufacturer ID	0x049E _h	
Device type ID	0x109C _h	
Polarity	Auto-MIDI-X	
Connections (max.)	CIP	12
	I/O	6
	Explicit Message	6
	Multicast	3 consumers
Minimum RPI	100 ms (default)	

Maximum RPI	10000 ms	
System integration	EtherNet/IP	EDS
	Rockwell	Add-on-Profile Level 3, Faceplate for FactoryTalk SE
IO data	Input (T --> O)	Device status and top-priority diagnostic message Measured values: <ul style="list-style-type: none"> ▪ 16 AI (analog input) + status + unit ▪ 8 DI (discrete input) + status
	Output (O --> T)	Actuating values: <ul style="list-style-type: none"> ▪ 4 AO (analog output) + status + unit ▪ 8 DO (discrete output) + status

15.8.6 Web server

The web server enables full access to the device configuration, measured values, diagnostic messages, logbooks and service data via standard WiFi/WLAN/LAN/GSM or 3G router with a user-defined IP address.

TCP port	80
Supported features	<ul style="list-style-type: none"> ▪ Remote-controlled device configuration (1 session) ▪ Device configuration saved/restored ▪ Logbook export (file formats: CSV, FDM) ▪ Web server accessed via DTM or Internet Explorer ▪ Login ▪ Web server can be switched off

15.9 Power supply

15.9.1 Supply voltage

CM442R

Depending on the version:

100 to 230 V AC \pm 15 %, 50/60 Hz

24 V AC/DC +20 / -15 %, 50/60 Hz

CM444R and CM448R

Depending on the version via external DIN rail power unit:

100 to 230 V AC \pm 15 %, 50/60 Hz

24 V DC +20 / -15 %

15.9.2 Cable specification

Display cable

Length of display cable supplied (only for optional display):

3 m (10 ft)

Maximum permitted length of a display cable:

5 m (16.5 ft)

15.9.3 Power consumption

CM442R

Depending on supply voltage

- 100 to 230 V AC and 24 V AC:

Max. 55 VA

- 24 V DC:

Max. 22 W

CM444R and CM448R

Depending on supply voltage

- 100 to 230 V AC:

Max. 150 VA

- 24 V DC:

Max. 59 W

15.9.4 Mains fuse

CM442R

5x20 mm, 250 V, 4.0 A, slow-blow (T4.0A)

CM444R and CM448R

Fuse is not exchangeable

15.10 Performance characteristics

15.10.1 Response time

Current outputs

t_{90} = max. 500 ms for an increase from 0 to 20 mA

Current inputs

t_{90} = max. 330 ms for an increase from 0 to 20 mA

Digital inputs and outputs

t_{90} = max. 330 ms for an increase from low to high

15.10.2 Reference temperature

25 °C (77 °F)

15.10.3 Maximum measured error sensor inputs

--> Documentation of the connected sensor

15.10.4 Measured error current inputs and outputs

Typical measured errors:

< 20 μ A (for current values < 4 mA)

< 50 μ A (for current values 4 to 20 mA)

each at 25 °C (77 °F)

Additional deviation depending on the temperature:

< 1.5 μ A/K

15.10.5 Frequency tolerance of digital inputs and outputs

\leq 1 %

15.10.6 Resolution of current inputs and outputs

< 5 μ A

15.10.7 Repeatability

--> Documentation of the connected sensor

15.11 Environment

15.11.1 Ambient temperature range

CM442R

0 to 60 °C (32 to 140 °F)

CM444R

- 0 to 55 °C (32 to 130 °F) in general, with the exception of the packages listed under the 2nd bullet point
- 0 to 50 °C (32 to 120 °F) for the following packages:
 - CM444R-***M40A7FI*+...
 - CM444R-***M40A7FK*+...

CM448R

- 0 to 55 °C (32 to 130 °F) in general, with the exception of the packages listed under the 2nd bullet point
- 0 to 50 °C (32 to 120 °F) for the following packages:
 - CM448R-***6AA*+...
 - CM448R-***8A4*+...
 - CM448R-***8A5*+...
 - CM448R-***28A3*+...
 - CM448R-***38A3*+...
 - CM448R-***48A3*+...
 - CM448R-***58A3*+...
 - CM448R-***68A3*+...
 - CM448R-***26A5*+...
 - CM448R-***36A5*+...
 - CM448R-***46A5*+...
 - CM448R-***56A5*+...
 - CM448R-***66A5*+...
 - CM448R-***22A7*+...
 - CM448R-***32A7*+...
 - CM448R-***42A7*+...
 - CM448R-***52A7*+...
 - CM448R-***62A7*+...

External display (optional)

–20 to 60 °C (0 to 140 °F)

15.11.2 Storage temperature

–25 to 85 °C (–13 to 185 °F)

15.11.3 Humidity

DIN rail device

5 to 85%, not condensating

External display (in installed state)

10 to 95%, not condensating

15.11.4 Degree of protection

IP 66 at front, if installed correctly and with appropriate protective enclosure

15.11.5 Climate class

As per IEC 60654-1: B2

15.11.6 Vibration resistance

Environmental tests

Vibration test based on DIN EN 60068-2, October 2008

Vibration test based on DIN EN 60654-3, August 1998

Wall mounting

Frequency range	10 to 150 Hz (sinusoidal)	
Amplitude	10 to 12.9 Hz:	0.75 mm
	12.9 to 150 Hz:	0.5 g ¹⁾
Test duration	10 frequency cycles/ spatial axis, in 3 spatial axes (1 oct./min)	

15.11.7 Electromagnetic compatibility

Interference emission and interference immunity as per EN 61326-1: 2006, class A for industry

15.11.8 Electrical safety

IEC 61010-1, Class I equipment

Low voltage: overvoltage category II

Environment < 2000 m (< 6562 ft) above MSL

15.11.9 Pollution degree

The product is suitable for pollution degree 2.

15.12 Mechanical construction

15.12.1 Dimensions

--> "Installation" section

15.12.2 Weight

Depending on version

CM442R (fully configured) Approx. 0.45 kg (1 lbs)

CM444R and CM448R (fully configured) Approx. 0.95 kg (2.1 lbs)

Individual module Approx. 0.06 kg (0.13 lbs)

External display (excluding cable) Approx. 0.56 kg (1.2 lbs)

External power unit (CM444R, CM448R) See Operating Instructions of power unit

15.12.3 Material

DIN rail housing	PC-FR
Display cover	PC-FR
Soft keys	EPDM
Display seal	EPDM
Module covers	PBT GF30 FR
Terminal strip	Nickel-plated brass
Ground terminals	Stainless steel 1.4301 (AISI304)
Screws	Stainless steel 1.4301 (AISI304)
Mounting plate (display)	Stainless steel 1.4301 (AISI304)
Securing screws (display)	Steel, galvanized

Index

A

Accessories	137
Activation codes	143
Extension modules	142
Measuring cable	137
SD card	145
Sensors	138
Software	144
Activation code	66
Activation codes	143
Additional functions	
Cleaning programs	98
Controller	89
Limit switch	84
Mathematical functions	104
Advanced setup	
Modbus	61
Alarm relay	
Cleaning	74
Controller	71
Diagnostics message	73
Limit switch	70
Approvals	14
Assignment views	53
Automatic hold	55

B

Basic settings	54
Basic setup	50
Binary inputs and outputs	76
Bus address	37, 60
Bus termination	36

C

Cable cross-section	153
Cable specification	146
Cable terminals	25
Calibration	130
cCSAus	14
CE mark	14
Check	
Function	48
Post-connection	38
Post-installation	21
Chemoclean	34, 99
Chemoclean Plus	100
Cleaning	
Assemblies	132
Chemoclean	99
Chemoclean Plus	100
Cycle	102
External display	131
Manual cleaning	103
Sensors	131
Standard cleaning	99
Cleaning assemblies	132
Cleaning programs	98
Cleaning sensors	131
Cleaning the display	131
Cleaning unit CAS40D	33
Climate class	159
Commissioning	48
Preparatory steps	37
Switching on the unit	48
Communication	
EtherNet/IP	42
Fieldbus	42
HART	42
Modbus	42
PROFIBUS	42
Service interface	41
Web server	39

Configuration	
Actions	46
Customized text	46
Display only	45
Numerical values	46
Picklists	45
Tables	47
Connection	
Cable terminals	25
Check	38
Chemoclean	34
Cleaning unit CAS40D	33
Current input	32
Current output	32
Digital input/output	31
Fieldbus	35
Relay	33
Sensors	28–30
Service interface	41
Supply voltage	26–27
Web server	39
Connection conditions	22
Controller	71, 89
Controller structure	89
Creating a connection	
Service interface	41
Web server	39
Current input	
Connection	32
Technical data	147
Current inputs	67
Current output	
Connection	32
Technical data	151
D	
Data management	
Activation code	66
Exporting the setup	65
Firmware update	64
Loading the setup	65
Saving the setup	64
Data transmission rate	148
Date and time	54
DDs	153
Declaration of Conformity	14
Degree of protection	37, 159
Designated use	7
Device architecture	11–12
Device behavior	116
Device description	10
Device description files	153
Device information	127
Device status	52
Device test	126
Device type	153
Device variables	74, 153
PROFIBUS	74
Device-specific errors	114
Diagnostic information	
Fieldbus	114
Onsite display	114
Web browser	114
Diagnostic list	121
Diagnostic message	
Classification	115
Device behavior, adjusting	116
Device-specific	118
Pending message	121
Sensor-specific	121
Diagnostics	
Device test/reset	126
Event logbook	121
Sensor information	128
Simulation	125
System information	127
Diagnostics settings	59
Digital input	147
Digital input/output	
Connection	31
Digital output	150
Dimensions	160
Display	43, 51
Assignment views	53
Device status	52
Measuring mode	51
Soft keys	51
Display cable	16, 156
Display icons	52
Display settings	48
Documentation	6

E

Electrical connection	22, 25–35
Functional ground	29
Mains fuse	156
Power consumption	156
Electrical safety	159
Electrical technician	22
Electromagnetic compatibility	8
EMC	159
Environment	
Ambient temperature range	158
Climate class	159
Degree of protection	159
Electrical safety	159
EMC	159
Pollution degree	159
Relative humidity	159
Storage temperature	158
Vibration resistance	159
Error categories	115
Ethernet	
Quick wiring guide	24
EtherNet/IP	62, 75
General	42
Quick wiring guide	24
Event logbook	121
Extended setup	
Data management	64
Diagnostics settings	59
EtherNet/IP	62
HART bus address	60
PROFIBUS	60
Webserver	63
Extension modules	142
External display	17, 19

F

Fieldbus	114
Module 485	35
Setting the address via the hardware	37
Termination	36
Fieldbuses	42
Firmware history	129
Firmware update	
Controller	64
Functional ground connection	29

G

Galvanic isolation	148
General settings	
Automatic hold	55
Basic settings	54
Date and time	54
Extended setup	59
Logbooks	56

H

HART	74
General	42
Quick wiring guide	22
HART version	153

I

Identification	
Nameplate	13
Serial number	14
Incoming acceptance	13
Input	
Cable specification	146
Current input	147
Digital input	147
Input signal	146
Input type	146
Measured variable	146
Measuring range	146
Numbering	11
Inputs	
Binary	80
Installation	15
Check	21
IT security	9

K

Keypad lock	45
-------------	----

L

Laplace representation	89
LEDs	35
Limit switch	70, 84
Linearization	149
Load	149
Locking operating keys	45
Logbooks	56, 121–124

M	
Mains fuse	156
Manufacturer ID	153
Material	160
Mathematical functions	
Degassed conductivity	106
Difference	104
Dual conductivity	107
pH calculation	108
Redundancy	105
rH value	106
Measured error	
Current inputs	157
Current outputs	157
Sensor inputs	157
Measured variable	146
Measuring cable	137
Measuring mode	51
Measuring range	146
Measuring range switch	109
Mechanical construction	
Dimensions	160
Material	160
Weight	160
Memosens	
Functional ground connection	29
Menu	
Basic setup	50
Display/Operation	48
Modbus	61
General	42
Quick wiring guide	24
Modbus RS485	75
Modbus TCP	75
Mounting conditions	
External display	17
Wall mounting	16
Mounting the measuring device	
DIN rail mounting	15, 18
External display	19
Wall mounting	19
N	
Nameplate	13
O	
Occupational safety	8
Onsite display	114
Operation	
Configuration	45
Display and operating elements	43
Operating concept	44
Via service interface	41
Via web server	40
Operational safety	8
Output	
Current output	151
Digital output	150
Linearization	149
Load	149
Numbering	11
Output signal	148
Protocol-specific data	153
Relay	152
Signal on alarm	149
Outputs	
Alarm relay	70
binary	81
Current outputs	68
Relay (optional)	70
P	
Pending diagnostic message	121
Performance characteristics	
Measured error	157
Reference temperature	157
Repeatability	157
Resolution	157
Response time	157
Pollution degree	159
Ports	11
Power consumption	156
Power supply	156
Process errors	113
Product identification	13
Product safety	9
PROFIBUS	60, 74
Device variables	74
General	42
PROFIBUS variables	75
Quick wiring guide	23
Protocol-specific data	153

R

Reference temperature	157
Relative humidity	159
Relay	33
Cable cross-section	153
Cleaning	74
Controller	71
Diagnostics message	73
Limit switch	70
Switching capacity	152
Relay types	152
Remote operation	
Ethernet	24
EtherNet/IP	24
HART	22
Modbus	24
PROFIBUS	23
Web server	24
Repeatability	157
Reset	126
Resolution	
Current inputs	157
Current outputs	157
Response time	157

S

Safety instructions	
Designated use	7
Occupational safety	8
Operational safety	8
Product safety	9
Scope of delivery	14
SD card	145
Security	
IT	9
Sensor information	128

Sensors

Chlorine	141
Conductivity, conductive	140
Conductivity, inductive	140
Connection	28–30
Enamel pH electrodes	138
Interface	142
ISE	141
Nitrate	142
ORP sensors	139
Oxygen	141
pH glass electrodes	138
pH-ISFET	139
SAC	142
Turbidity	142
Types	28
Serial number	14
Service interface	
Connection	41
Creating a connection	41
Setting the operating language	48
Setup	
Export	65
Load	65
Save	64
Signal encoding	148
Simulation	125
Slots	11
Soft keys	51
Spare parts	133
State of the art	9
Status display	43
Storage temperature	158
Supply voltage	156
CM442	26
CM444/CM448	27
Switching on the unit	48
Symbols	5
System information	127
System integration	39

T

Technical data 146
 Environment 158
 Input 146
 Mechanical construction 160
 Output 148
 Performance characteristics 157
Terminal diagram 12
Troubleshooting 113–121

U

Use 7

V

Vibration resistance 159

W

Warnings 5
Web browser 114
Web server 63
 Connection 39
 Creating a connection 39
 Operation 40
 Quick wiring guide 24
Weight 160

www.addresses.endress.com
