

EN - For pricing and availability in your local country please visit one of the below links:

DE - Informationen zu Preisen und Verfügbarkeit in Ihrem Land erhalten Sie über die unten aufgeführten Links:

FR - Pour connaître les tarifs et la disponibilité dans votre pays, cliquez sur l'un des liens suivants:

[WH25 4K7JI](#)

[WH5 33R JI.](#)

[WH10-12RJI.](#)

[WH50-20RJIB006](#)

[WH25-12RJI.](#)

[WH5-6R8JI.](#)

[WH10-15RJI..](#)

[WH10-15RJI.](#)

[WH25-24RJI..](#)

[WH25-56RJI..](#)

EN

This Datasheet is presented by
the manufacturer

DE

Dieses Datenblatt wird vom
Hersteller bereitgestellt

FR

Cette fiche technique est
présentée par le fabricant

Aluminium Housed Wirewound Resistors

WH Series

- High power dissipation up to 300W
- All welded construction
- Suitable for severe environments
- Designed for excellent thermal conductivity to heatsink
- Spade terminal option
- RoHS compliant

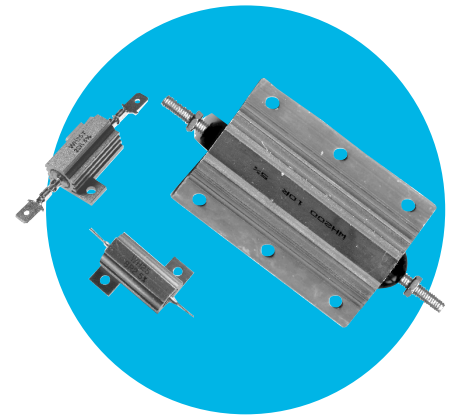

 All Pb-free parts comply with EU Directive 2011/65/EU (RoHS2)

Electrical Data

		WH5	WH10	WH25	WH50	Notes
Power rating at 25°C	watts	10	15	25 ²	50 ^{1, 2}	On standard heatsink
Resistance range	ohms	0R01 to 10K	0R01 to 20K	0R01 to 44K	0R015 to 120K	
TCR (-55° to 200°C)	ppm/°C	<10R: ±75 ≥10R to <100R: ±50 ≥100R: ±25				
Resistance tolerance	%	1(F), 2(G), 5(J) and 10(K)				
Low value limits	ohms	1R at 1%	0R5 at 2%	0R05 at 5%	0R01 at 10%	WH50 0R015 at 10%
Isolation voltage	volts	1500	1500	3000	3000	DC or AC peak

Note 1: For load at full rating mount on aluminium heatsink 30.5 cm x 30.5 cm x 1.5 mm Note 2: WH25T & WH50T are additionally rated at 15A

CECC 40203-006 Requirements *		AA	BA	CA	DA	Notes
Power rating at 25°C	watts	10	15	25	40	On standard heatsink
Resistance range	ohms	0R05 to 3K4	0R05 to 15K	0R05 to 33K	0R05 to 82K	
TCR (-55° to 200°C)	ppm/°C	≥5R to ≤10R: ± 100 >10R: ±50				
Resistance tolerance	%	1(F), 2(G), and 5(J)				
Low value limits	ohms	1R at 1% 0R5 at 2% 0R05 at 5%				
Isolation voltage	volts	1000	1000	2000	2000	DC or AC peak

* This table indicates the CECC specification requirements which are met or exceeded by the corresponding WH series products.

Limiting element voltage	volts	150	250	500	1250	DC or AC rms
Standard values		E24 preferred range				Other values to order
Thermal impedance	°C/watt	16.0	10.0	6.0	3.5	On standard heatsink
Ambient temperature range	°C	-55 to 200				

		WH100	WH200	WH300	Notes
Power rating at 25°C	watts	100	200	300	On standard heatsink
Resistance range	ohms	0R01 to 70K	0R01 to 50K	0R01 to 68K	
TCR (-55° to 200°C)	ppm/°C	≤1K0: ±100 >1K0: ±25			
Resistance tolerance	%	Standard 5(J) and 10(K). also available : 1(F) and 2(G)			
Low value limits	ohms	Typically ≥0R05: ±5% ≤0R047: ±10%			
Isolation voltage	volts	6360	7070	7070	DC or AC peak
Limiting element voltage	volts	1900	1900	2500	DC or AC rms
Standard values		E24 preferred range			Other values to order
Thermal impedance	°C/watt	1	0.7	0.6	On standard heatsink
Ambient temperature range	°C	-55 to 200			

General Note

TT Electronics reserves the right to make changes in product specification without notice or liability.
All information is subject to TT Electronics' own data and is considered accurate at time of going to print.

WH Series

Physical Data

Dimensions (mm) & Weight (g)														
WH5, 10, 25 & 50														
Type	A	B	C	E	F	G	H	L	M	N	Dt	Wt.		
	Max	±0.3	±0.3	Min	Max	Max	Dia ±0.2	Max	±0.5	Max	Min	Nom		
WH5	30	12.4	11.3	1.9	17	9	2.4	17.0	4.3	1.8	2.5	3.6		
WH10	36.5	15.9	14.3	1.9	21	11	2.4	21.0	5.2	2.2	2.9	5.6		
WH25	51 ¹	19.8	18.3	2.8	28	15	3.3	29.0	7.2	2.6	4.3	13		
WH50	72.5 ²	21.4	39.7	2.8	30	16	3.3	51.0	7.9	2.6	5.1	29		
WH100, 200 & 300														
	A Max	B Max	C Max	D Max	E Max	F ±0.3	G ±0.3	H Max	J Max	K Max	L Nom ³	M Max	Dt Min	Wt. Nom
WH100	47.5	88	24.1	27.3	65.2	35	37	11.8	15.4	3.7	4.4	-	7.0	115
WH200	72.5	145.7	41.8	45.5	89.7	70	57.2	20.5	10.4	5.5	5.1	103.4	15	475
WH300	72.5	184.4	41.8	45.5	127.7	104	59	20.5	12.4	5.5	6.6	141.4	15	700

Note 1: A_{max} for WH25T is 71.3

Note 2: A_{max} for WH50T is 95.5

Note 3: WH100: ±0.25, WH200 & 300: ±0.45

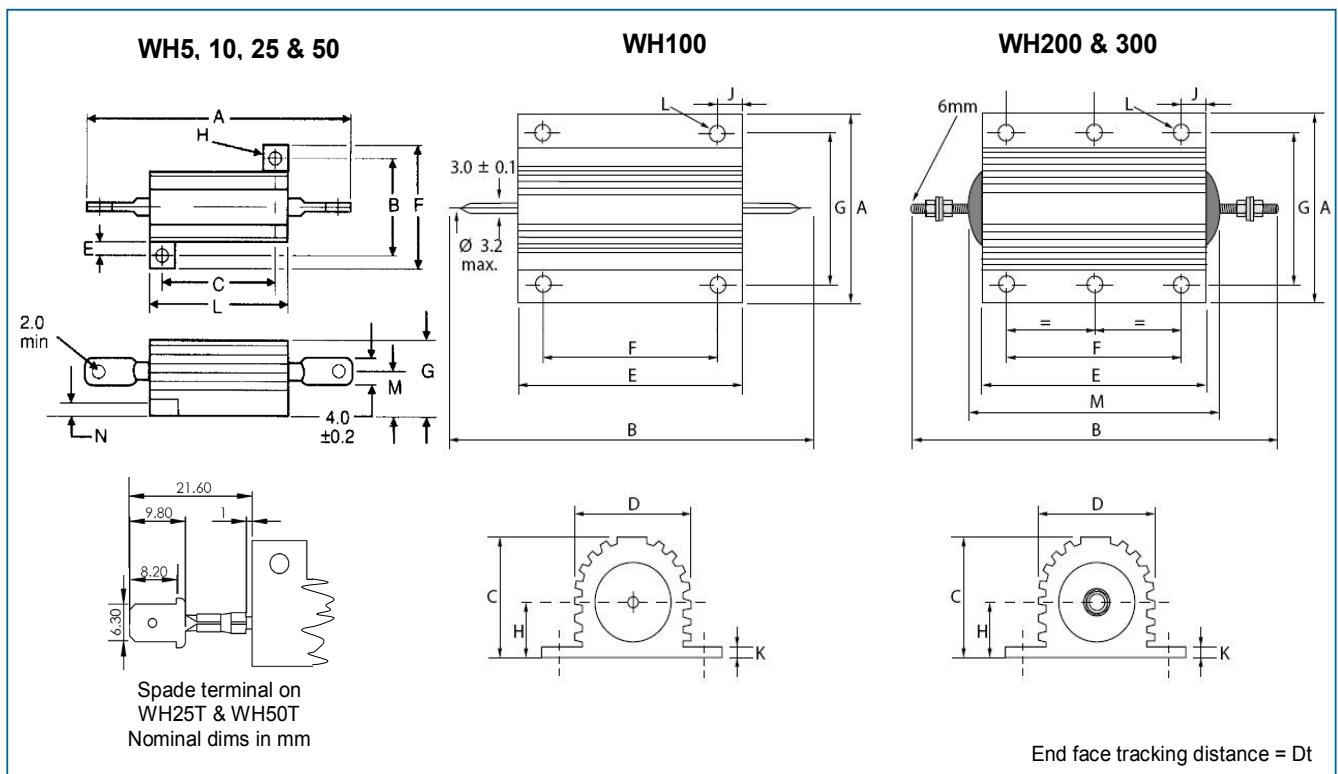

Construction

Cap and lead assemblies are fitted to a high purity ceramic substrate. The resistive element is wound onto the substrate and welded to the caps. The wound rod is then moulded and fitted into aluminium housing to give optimum stability and reliability.

Marking

The resistors are legend marked with type reference, resistance value and tolerance which will withstand all accepted industrial cleaning fluids. Values are marked in accordance with IEC 62

General Note

TT Electronics reserves the right to make changes in product specification without notice or liability. All information is subject to TT Electronics' own data and is considered accurate at time of going to print.

WH Series

Terminations

WH5-100

Material Pb-free solder dipped, copper clad steel

Strength The terminations meet the requirements of IEC 68.2.21

Solderability The terminations meet the requirements of IEC 115-1, clause 4.17.3.2

WH25T & 50T 6.35mm (1/4") spade terminal

WH200 & 300

Material M6 threaded steel terminal with a set of four nuts and washers

Strength Termination robustness 50N max
Tightening torque 5Nm max

Performance Data

		WH5, 10, 25 & 50			WH100, 200 & 300
		CECC 40203-006 Requirements	Actual		Maximum
			Maximum	Typical	
Load at commercial rating: 1000hrs at 25°C	ΔR%	1	1	0.4	2
Load at CECC rating: 1000hrs at 25°C	ΔR%	1	1	0.4	N/A
Dry heat: 1000hrs at 200°C	ΔR%	1	1	0.4	2
Derating from 25°C		Zero at 200°C, see derating graph			
Short-term overload	ΔR%	1	1	0.2	
Climatic sequence	ΔR%	1	1	0.4	
Climatic category		55/200/56			
Long-term damp heat	ΔR%	1	0.5	0.2	
Temperature rapid change	ΔR%	0.25	0.25	0.1	0.25
Resistance to solder heat	ΔR%	0.25	0.25	0.05	WH100: 0.5
Vibration and bump	ΔR%	0.25	0.25	0.025	
Noise (in decade of frequency)	μV/V	Not specified	0	0	0
Insulation resistance	ohms	1G min			10G min
Pulse and overload performance		Not specified			See graphs

Note: A 0.05 ohm addition is to be added to the performance of all resistors < 10 ohms.

Pulse and Overload Performance

For short durations of ≤0.1s the energy graph should be used. For longer durations the overload graph applies.

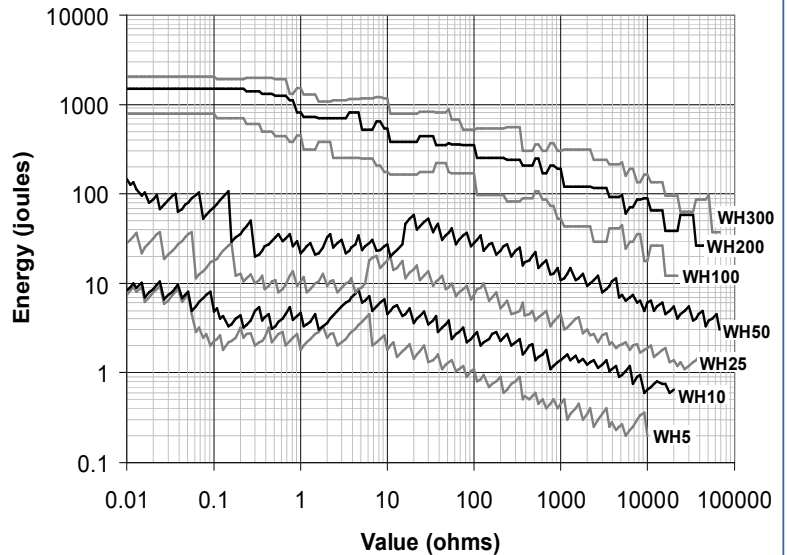
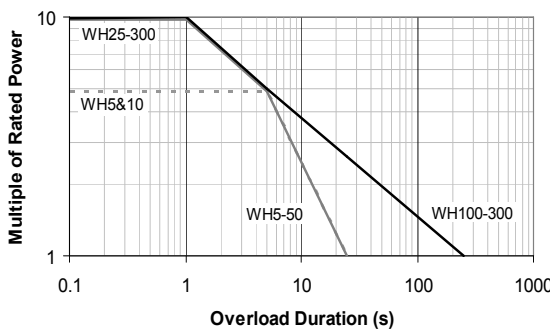

Application Notes

After soldering, care should be taken to ensure that there are no flux residues on the end faces of the moulding compound, otherwise insulation resistance will be reduced. The minimum surface tracking distances from termination to casing are shown in the Physical Data tables as dimension Dt.

It is recommended that the resistor base should be coated thinly with heatsink compound before mounting to obtain the stated operating characteristics. The heatsink compound increases thermal conductivity to the heatsink.

General Note

TT Electronics reserves the right to make changes in product specification without notice or liability. All information is subject to TT Electronics' own data and is considered accurate at time of going to print.

WH Series

The standard aluminium heatsinks are defined in the table below. If smaller heatsinks are used then derating should be applied as indicated in the graph below. If no heatsink is employed, use the ratings for 1cm².

Reference heatsink dimensions

Type (CECC)	Thickness (mm)	Area (cm ²)
WH5 (AA)	1	410
WH10 (BA)	1	410
WH25 (CA)	1	544
WH50 (DA)	1	544
WH50 @ 50W	1.5	930
WH100	3	1000
WH200	3	3800
WH300	3	5800

Derating for reduced heatsink dimensions

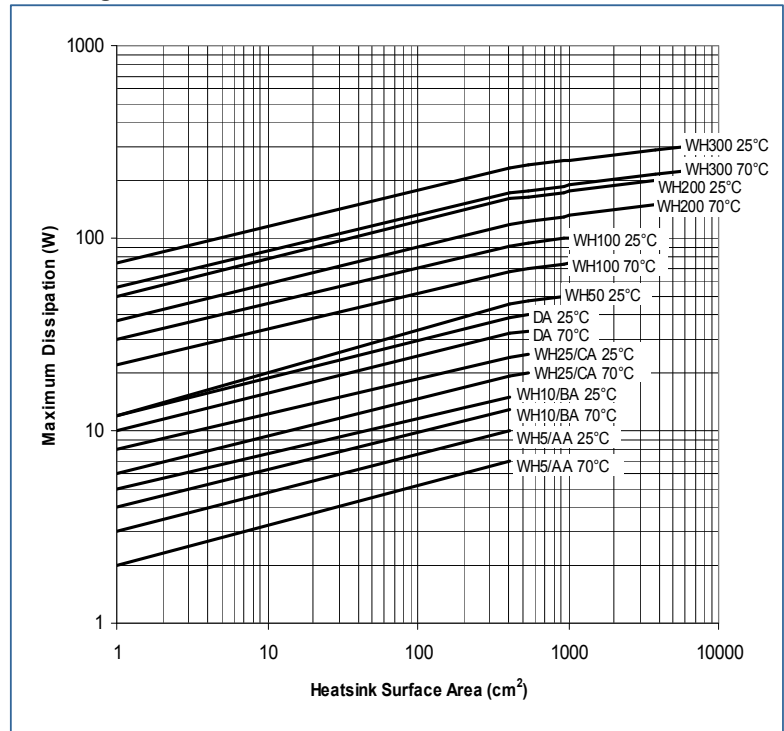

Derating for ambient temperature

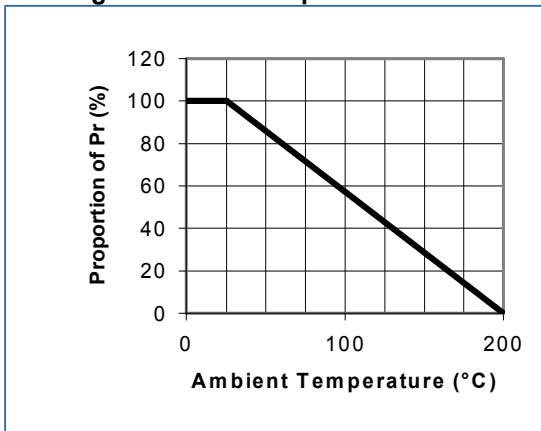

Packaging

WH resistors are packed in plastic bags and boxed.

Ordering Procedure

Example: WH25 with spade terminals at 100 ohms with a 5% tolerance:

WH25T-100RJ I

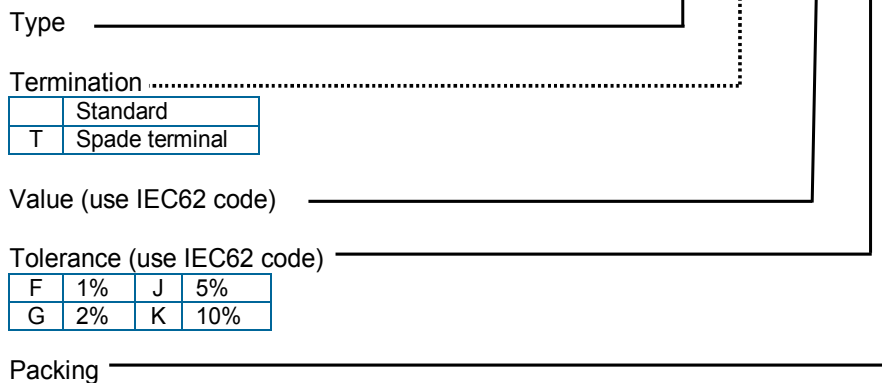

I	WH5, 10	Bulk	250/box	Standard
	WH25, 50		200/box	
	WH100		45/box	
	WH200, 300		10/box	

The following options apply to WH5, 10, 25 & 50 only:

For CECC released product state on order the CECC number and style. Example: **WH25-3K3JI CECC40203-006 CA**

For SnPb finish instead of Pb-free replace the packing suffix with PB. Example: **WH25-3K3JPB**

General Note

TT Electronics reserves the right to make changes in product specification without notice or liability. All information is subject to TT Electronics' own data and is considered accurate at time of going to print.

[WH5-2R7JI..](#)

[WH5-6R8JI..](#)

[WH50-1R5JI..](#)

[WH25-120RJI.](#)

[WH25-6R8JI..](#)

EN - For pricing and availability in your local country please visit one of the below links:

DE - Informationen zu Preisen und Verfügbarkeit in Ihrem Land erhalten Sie über die unten aufgeführten Links:

FR - Pour connaître les tarifs et la disponibilité dans votre pays, cliquez sur l'un des liens suivants:

[WH25 4K7JI](#)

[WH5 33R JI.](#)

[WH10-12RJI.](#)

[WH50-20RJIB006](#)

[WH25-12RJI.](#)

[WH5-6R8JI.](#)

[WH10-15RJI..](#)

[WH10-15RJI.](#)

[WH25-24RJI..](#)

[WH25-56RJI..](#)

EN

This Datasheet is presented by
the manufacturer

DE

Dieses Datenblatt wird vom
Hersteller bereitgestellt

FR

Cette fiche technique est
présentée par le fabricant